

GEYSER Sky R0

20÷30 kW



General

Range of reversible heat pumps featuring variable speed scroll compressors with extended operating limits

Configurations

Hi HP: Reversible heat pump version, with inverter compressor

/SLN: super low-noise unit

Strengths

- ▶ Refrigerant R290 - GWP≈0. The refrigerant is a pure natural fluid.
- ▶ Reduced refrigerant charge
- ▶ Extended operating limits: the ideal solution to replace boilers
- ▶ Domestic hot water managed via a 3-way valve, either integrated or external
- ▶ Production of hot water up to 78°C
- ▶ Operation down to ambient -20°C with outlet water at +60°C
- ▶ 4.3" touch screen interface
- ▶ Eurovent Certification

BlueBox 
by Swegon

GEYSER Sky R0

Product description	3
Description of accessories	7
Refrigerant circuit accessories	7
Fan accessories	7
Hydraulic circuit accessories	7
Electrical accessories	24
Network accessories	29
Other accessories	32
Technical specifications	33
Ecodesign	35
Electrical specifications	39
Hydraulic modules	40
Pump data	41
User-side exchanger flow rate fields	42
Operating limits	43
Noise levels	45
Installation advice	46
Water characteristics	46
Glycol mixtures	46
Minimum water content in the system	47
Installation site	48
Definitions	49
Applicable standards and regulations	50
Installation types	50
Class III hydronic unit installations in open air environments	51
Class IV installations (indoor units)	53
Hydraulic Connections	54
Guidelines for the risk assessment	55
Installation risk assessment	57
Suggestions for conducting and drawing up the risk assessment	60
Installations that require the use of treated coils	64
Dimensional diagrams	65



GEYSER Sky R0

PRODUCT DESCRIPTION

Range of reversible heat pumps featuring variable speed scroll compressors optimised for use with natural propane refrigerant

REFRIGERANT

The models from the Geysler Sky series are available with refrigerant R290.

The use of R290 refrigerant is indicated by acronym "R0", which indicates a GWP level close to 0.

Refrigerant R290 GWP(Global Warming Potential)=3*

ODP (Ozone Depletion Potential) 0

The refrigerant is a pure natural fluid.

R290 is classified as group 1 fluid according to PED.

It is also classified as A3 according to ASHRAE standard 34:

- non-toxic;
- Highly flammable.

The excellent GWP value may be an advantage in projects where:

- min. targets are adopted for the containment of the environmental footprint;
- it is possible to receive incentives or other benefits that are applicable in some countries or are connected to specific plant design criteria.

(*) GWP (AR5), pursuant to IPCC V, evaluated over a span of 100 years.

STRUCTURE

The structure of the unit is made of galvanized sheet-iron coated with polyester powder in RAL 5017/7035 at 180°C, which makes it highly resistant to weather conditions.

The structure is a load-bearing frame, with removable panelling lined with sound absorbing expanded polyurethane matting.

All bodies have a condensation collection tank with drain.

COMPRESSORS

Hermetic scroll compressor, complete with thermal overload protection included in the electric motor windings, crankcase heater and rubber vibration damping supports. The compressor is specifically designed for operation in heat pump mode. Additionally, the optimized compression ratio at high operating pressures allows for higher efficiency if compared with conventional scroll compressors.

The compressor is optimised for use with propane.

The compressor is enclosed in a dedicated technical compartment, access to which is gained by removing the installed panelling.

The compressor is coupled with an inverter to perform speed modulation.

The modulating compressor is a hermetic scroll compressor with a permanent magnet brushless motor.

The speed of the modulating compressor is varied, depending on the total heat load, roughly between 30 and 105 rps. 20rps and up to 120rps

The speed of rotation of the compressor is variable in the range 1200÷7200 rpm.

The modulating compressors are driven by inverters. This also has the following functions:

- management of acceleration and deceleration ramps
- management of the operating envelope of the modulating compressor
- management of the alarms and safety devices of the modulating compressor

The use of a modulating compressor allows the total inrush current to be reduced because it is always started with an acceleration ramp.

SOURCE-SIDE HEAT EXCHANGER

It consists of a coil with copper tubes and aluminium fins having a large exchange surface with fin pitch sized to maximize heat exchange and to reduce the noise impact.

The coils have an increased fin pitch to reduce frost formation and to facilitate the outflow of condensed water during defrosting.

The finned coil is installed as standard including suitable hydrophilic treatments for easier condensed water drainage from the coil.

Options are available for installations in environments with especially aggressive atmospheres, in areas along the coast or in highly industrialized zones. Ref. section: "Description of options".

For installations within a kilometre of the coast, the use of Cu/Al coils with anti-corrosion treatment is strongly recommended.

At the base of the coils there is a collection tray as standard which facilitates the drain of condensate during the defrost.

The unit is fitted as standard with a heating cable glued to the bottom of the condensate tray to prevent formation of ice.

RAM accessory provide an oversized electrical heaters system.

Heaters are managed with a thermostat , activated depending on outside air temperature.

Recommended accessory for installations in regions with temperatures below -5°C or in the case of installations particularly exposed to cold winds.

USER-SIDE HEAT EXCHANGER

The exchanger is a braze-welded stainless steel plate heat exchanger, insulated with a shroud of closed-cell insulating material.

The exchanger is also equipped with thermostat-controlled anti-freeze heater to protect it from ice formation when the unit is not running.

The operation of the unit is optimized in heating mode, where the water and refrigerant fluids exchange in counter-current inside the plate heat exchanger.

FANS

The fans are axial fans, directly coupled to a 6-pole electric motor, with integrated thermal overload protection (Klixon®) and IP 54 protection rating.

The fan includes the shroud, designed to optimize its efficiency and reduce noise emission to a minimum, and the safety guard.

The control manages the speed of the fans through a phase cutting speed adjuster, in order to optimize the operating conditions and efficiency of the unit.

The fan speed regulator is supplied standardly.

This control also has the effect of reducing the noise level of the unit: in fact, the typical conditions under which the control will be modulating the speed of the fans are those of the night, spring and autumn.

For units equipped with EC fans (option), the same function is carried out using the electronically commutated motor of the fans.

REFRIGERANT CIRCUIT

Each refrigerant circuit comprises:

- charging valve
- liquid sight glass
- non-return valve
- 4-way reversing valve
- dehydrating filter
- liquid receiver
- electronically-controlled thermostatic expansion valve
- pressure transducer
- high pressure switch with manual reset
- suction liquid separator
- safety valves

The copper pipes are sized with increased thicknesses in order to ensure greater reliability and durability over time.

The pipes of the circuit and the exchanger are insulated with extruded closed-cell expanded elastomer.

The refrigeration circuit is enclosed in a compartment that contains an ATEX certified leak sensor and an ATEX certified extraction fan.

The hydronic module, if present, is also enclosed in the compartment that contains the ATEX certified leak sensor and the ATEX certified extraction fan.

ELECTRICAL CONTROL PANEL

The electrical control panel is made in a painted galvanized sheet-iron box with forced ventilation and IP54 protection rating.

The electrical panel is made following the EN60204-1 standard.

The electrical panel is separated from the compressor compartment.

The electrical control panel comprises:

- general disconnect switch three-phase line
- a compressor contactor;
- fan contactors
- fuses to protect the compressors, fans and auxiliary circuits
- a fan speed regulator for condensate control;
- thermal magnetic circuit breakers for pumps (if present)
- phase monitor
- general alarm potential free contacts.
- single potential free operating contacts for compressors, fans and pumps (when present)
- external air temperature probe

The electronic controller is designed for management of the following functions:

- water temperature regulation, with outgoing water control;
- freeze protection;
- compressor time setting;
- alarm signals;
- alarm resetting;
- summer/winter selection by digital input
- digital input for external ON-OFF switching.

The display shows the following parameters:

- output water temperature;
- temperature and differential setpoints;
- alarms description.

All the electrical cables inside the panel are numbered and the terminal board dedicated to the customer's connections is coloured orange so that it can be quickly identified in the panel.

The unit power supply is 400V/3~+N/ 50Hz for all models.

The graphic terminal is a 4.3" touch screen panel.

The touch screen panel is also designed for easier man-machine interaction as it makes screen browsing much more user-friendly.



CONTROL BLUETHINK

The unit is supplied as standard with an advanced controller.

The control allows the following functions:

- water temperature regulation, with outgoing water control;
- freeze protection
- recording of the log of all machine inputs, outputs and states
- automatic rotation of compressor starting sequence
- recording of the alarm log
- RS485 serial port with Modbus protocol
- Ethernet serial port with Modbus protocol and integrated web server preloaded web page
- digital input for general ON/OFF
- digital input for Summer/Winter selection

For further details on available functions and on displayed information, refer to the specific documentation of the controller.

By default, the serial connections present as standard are enabled only for reading from BMS. Enabling of writing from BMS is to be requested when ordering.

Main functions of the webserver

As standard, the Bluethink controller integrates a webserver with a preloaded web page that is accessed via password.

The web page allows the following functions to be carried out (some of these are available only for users with advanced level rights):

- display of the main functions of the unit such as unit serial n°, size, refrigerant
- display of the general status of the machine: water inlet and outlet temperatures, external air temperature, mode (chiller or heat pump), evaporating and condensing pressures, suction and discharge temperatures
- display of the status of compressors, pumps, expansion valves
- display in real time of the graphs of the main quantities
- display of the graphs of logged quantities
- display of alarm log
- management of users on several levels
- remote ON/OFF
- remote set point change
- remote time band change
- remote summer winter mode selection

Human-Machine Interface

The control has a graphic display that allows the following information to be displayed:

- water inlet and outlet temperature
- set temperature and differential set points
- description of alarms
- hour meter of operation and number of start-ups of the unit, the compressors and the pumps (if present)
- high and low pressure values, and relevant condensing and evaporating temperatures
- external air temperature
- superheating at compressor suction.

Management of defrost cycles

For defrost management, the control of the unit uses a sliding intervention threshold, depending on the pressures inside the unit and the external air temperature. By putting together all this information, the control can identify the presence of ice on the coil and activates the defrosting sequence only when necessary, so as to maximize the energy efficiency of the unit.

Sliding management of the defrost threshold ensures that, as the absolute humidity of outdoor air decreases, the frequency of the defrost cycles gradually decreases because they are carried out only when the ice formed on the coil actually penalizes performance.

The defrost cycle is fully automatic: during the initial stage, a defrost is carried out by cycle reversal with the fans stopped. As soon as the frost on the coil has molten to a suitable level, the unit resumes operation in heat pump mode.

Management of an additional external heat source

The controller is designed to control an external heat source which can be used in integrative mode or as a backup system, depending on the hydraulic connections. The diagram below, for instance, shows a boiler used as a backup system to the heat pump, when necessary.

Activation of the auxiliary source takes place when the temperature of the outside air falls below a minimum temperature threshold that can be set in the controller and when the heat pump alone is insufficient to meet the required load. Activation takes place by closing a potential free contact.

It is also possible to set the unit so that the controller switches off the compressors when the unit is operating in heat pump mode and the outside air temperature falls below a minimum set point: the controller will stop the compressors before the unit goes into low pressure alarm, which would require a manual restart of the unit.

This function is particularly useful when the heat pump is installed in areas where the outside air temperature will certainly fall below the minimum temperature allowed for correct operation (in accordance with the predefined set point). When the temperature of the outside air exceeds again the minimum threshold for correct operation, the unit will resume correct operation in heat pump mode, without requiring any action.

If the unit is supplied with an on-board pump, the pump will continue to operate and to circulate the water, thus preventing the formation of ice and at the same time providing for correct reading of the water temperature and correct reading by the freeze safety probes.

The stopping temperature must be set up based on the temperature of the highest set point and in line with the operating limit of the unit. The stopping temperature can be different from the predefined temperature, provided that it is in any case in line with the temperature limits of the machine. If the unit must be also used for the production of domestic hot water, the stopping temperature must be set up according to the highest water set point and the allowed operating limits.

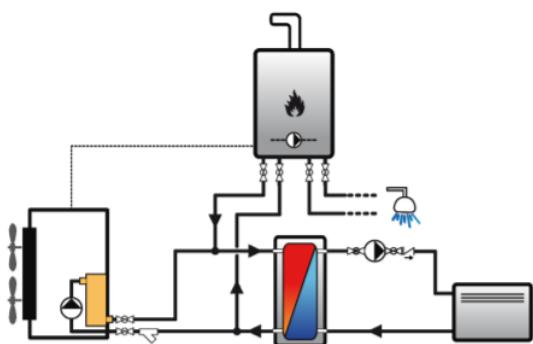

OPTIONS

/SLN: super low noise unit

The standard unit requires all compressors to be enclosed within a fully acoustically insulated compartment with sound-absorbing material with interposed sound-proofing material.

The SLN version units use fans with speed regulators with reduced air flow in chiller operation. The speed reduction of the fans is such that, under nominal operating conditions, the air flow rate and noise level are lower than those of the basic version of the unit.

In any case, the use of the speed adjuster to reduce the air flow rate allows rotation of the fans at maximum speed when external air temperature conditions are particularly critical and therefore guarantees the same operating limits as the high efficiency version.

In heating mode, the fans always run at 100% speed.

HYDRAULIC MODULES

All units can be fitted with hydraulic module in various configurations:

- /1P: hydraulic module with one pump
- /1PS: hydraulic module with one pump and buffer tank

Hydraulic modules with one pump have:

- one pump
- an expansion vessel

Hydraulic modules with tank also have:

- a gate valve at the inlet of the pump or the suction manifold
- a tank with drain valve and air valve

INSPECTIONS AND SAFETY

All the units are fitted with the following control and safety components:

- user-side water temperature probe
- antifreeze probe on the user side heat exchanger
- high pressure switch with manual reset
- low pressure safety device with automatic reset, for a limited number of occurrences, managed by the controller
- compressor overtemperature protection
- fan overtemperature protection
- differential flow switch
- ATEX certified leakage sensor
- ATEX certified extraction fan

In the event that the leak detector identifies a gas leak, the following safety procedures are implemented:

- immediate shutdown of the unit
- interruption of the three-phase main power supply
- activation of the extraction fan
- activation of the ventilation fans of the electrical panel

TESTING

All the units are factory-tested and supplied complete with oil and refrigerant.

PACKAGING

The unit is made and shipped on a wooden pallet that allows the unit to be handled using a forklift truck.

The unit is wrapped in a protective transparent polyethylene stretch film.

DESCRIPTION OF ACCESSORIES

Refrigerant circuit accessories

BK Brine Kit

This accessory is compulsory if a water temperature set point lower than +5°C is used (if the unit is provided with double set point or variable set point, the lower set point is considered).

The accessory consists of increased insulation and suitable sizing and calibration of some components.

The inlet and outlet temperatures of the user-side exchanger must be given on ordering to allow correct setting of the alarm parameters and verification of the sizing of the expansion valve.

The cooling set point can then be changed by the customer in an interval that, compared to the set point given on ordering, ranges from -1K up to the maximum temperature allowed by the above-stated operating limits.

The unit will be optimized to work at the set point temperature given on ordering. For different set points, the cooling capacity provided and the level of efficiency of the machine could decrease and move away from these conditions.

VS Liquid line solenoid valve

This accessory prevents refrigerant migration that could damage the compressor on starting.

Fan accessories

VEC EC fans

With this accessory, EC fans, with electronically commutated brushless motor, are used for the ventilating section. These guarantee very high efficiency levels for all working conditions and allow a 15% saving on the power absorbed by each fan working at full capacity.

Through a 0-10V analogue signal sent to each fan, the microprocessor also carries out condensation control by continuous adjustment of the air flow rate as the external air temperature changes, with a further reduction in electrical absorption and noise emission.

For further details, see the dedicated chapter: "Aeraulic head losses and options available for the fan section".

Hydraulic circuit accessories

RA Antifreeze heater

These are electric heaters inserted on the user-side heat exchanger, on the pumps and in the tank (depending on the configuration of the machine) to prevent damage to the hydraulic components due to ice formation during periods when the machine is stopped.

Based on normal operating conditions and the percentage of glycol in the system, an appropriate "antifreeze alarm" temperature is set in the control. When a temperature that is 1K higher than the antifreeze alarm threshold is detected at the outlet from the exchanger, the pump (if present) and the antifreeze heaters are switched on. If the temperature of the outgoing water reaches the antifreeze alarm threshold, the compressors are stopped, keeping the heaters and the pumps active, and the general alarm contact of the machine is activated.

RINT Additional heaters (on user side)

The accessory requires an additional immersed heater to be installed directly in the tank of the hydraulic module.

The additional heater is activated only when:

- the unit is in heat pump mode
- the external air temperature is below a settable threshold (service parameter)
- the tank inlet water temperature is below a settable threshold (service parameter)

The additional heaters can have a different capacities depending on the machine model, and they can be managed with stepped control (up to 4 steps).

FW Water filter

To protect the elements of the hydraulic circuit (in particular, the exchangers), there are Y filters that can stop and settle the particles that are normally present in the water flow and would otherwise settle in the more delicate parts of the hydraulic circuit and damage its heat exchange capacity.

Installation of the water filter is mandatory even when it is not supplied as an accessory.

V3E External 3-way valve for domestic hot water management

This is a three-way on-off valve, complete with servo control. The unit controller can manage two separate hydraulic circuits through this valve: one for comfort and one for domestic hot water production.

The valve and the servo control are for indoor installation and they require the ambient temperature not to drop below -10°C .

Accessory supplied loose. Installation by the customer.

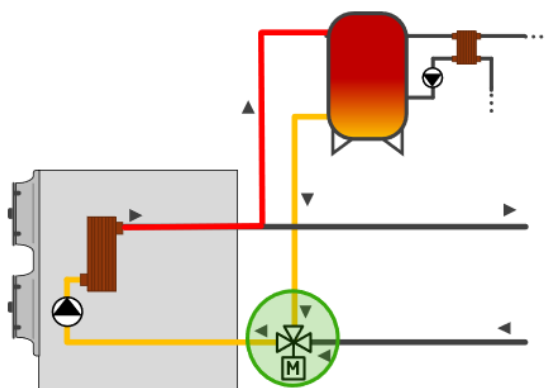

V3I Integrated 3-way valve for domestic hot water management

This is a three-way on-off valve, complete with servo control. The unit controller can manage two separate hydraulic circuits through this valve: one for comfort and one for domestic hot water production.

The valve and servo control are installed in the unit.

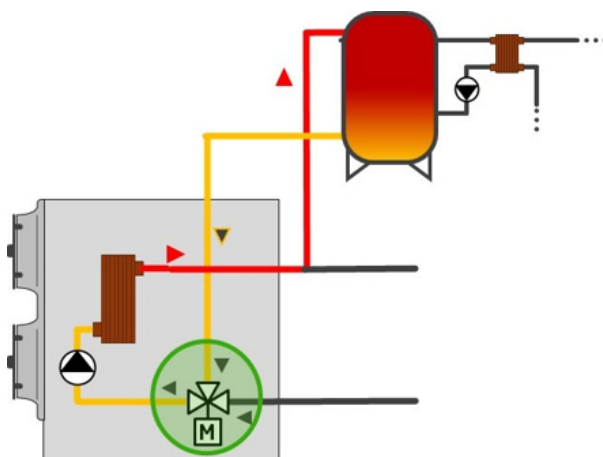

Flowzer options

Our range of Flowzer options offers flexible and scalable solutions to set the speed of pumps in the system with a view to optimising and reducing energy consumption. Different types of control modes are offered based on the system and application type:

- FLOWZER VP - Inverter for manual pump adjustment
- FLOWZER VD - control of available pump discharge head for variable flow systems without monitoring the flow rate limits;
- FLOWZER VDE - flow rate control to keep the flow rate constant as the external working conditions of the system change;
- FLOWZER VDT - flow rate control with constant TD (difference between input and output temperature in the heat exchanger on the user side) in variable flow pumps, without monitoring the flow rate limits;
- FLOWZER VFPP - automatic management of variable flow rate in systems with one single primary circuit and a bypass valve;
- FLOWZER VPS - automatic management of variable flow rate, including balancing of flow rates between primary and secondary circuits;
- flowzer vps with TD-based control - automatic management of variable flow rate, including control with constant TD (difference between input and output temperature in the heat exchanger on the user side) in systems featuring both the primary and secondary circuits.

The tables below summarise the main system diagrams and show the application type and advantages/disadvantages offered by each solution. Each individual option is illustrated and explained individually in the next pages.

The hydraulic diagrams in this document are for exemplification purposes only and their main function is to help the reader understand the type of machines and devices the controller can manage. For a more technical evaluation of the system, please refer to the dedicated manual.

Constant flow system			
	Application	Advantages	Disadvantages
Flowzer VP	Ideal for constant flow systems The option is given to set two different speeds: one for heating and one for cooling mode or one for chiller and one for FC mode. This solution replaces the 2-way regulating valve.	- Increased efficiency: increased "REAL" EER of the unit installed, considering the power consumption of the pumps in real installation conditions and in real operating conditions. - Reduced installation times and costs: quick setup of water flow using the display.	This solution doesn't allow to save energy in the pump under part load conditions, due to the possibility to only set two frequency values in the inverter.
Flowzer VDE	Ideal for constant flow systems to keep the water flow to the heat exchanger constant under all conditions	- Plug&Play: provides for easy and flexible implementation as it is not supplied with options to be fitted therefore allows for quick commissioning.	This solution is less efficient as losses in the heat exchanger are kept constant under all conditions (including in cases when they may be reduced).

FLOWZER VP

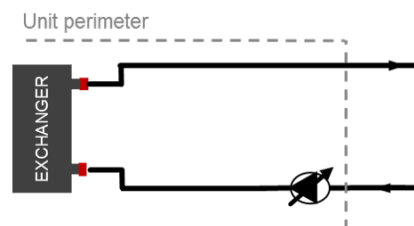

FLOWZER VDE

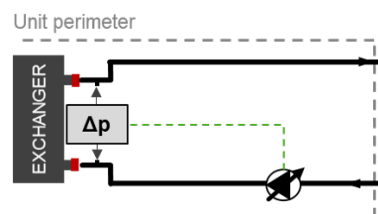

Variable flow system featuring primary and secondary circuits

	Application	Advantages	Disadvantages
Flowzer VPS	Ideal for all systems featuring a primary and a secondary circuit divided by a hydraulic bypass branch	- Energy saving: the energy consumption during pumping operations can be cut down to 55% if compared with a traditional system - Enhanced comfort: correct balancing between primary and secondary loop	Only recommended in systems featuring a primary and a secondary circuit divided by a bypass pipe; not flexible for other applications
Flowzer VDT	Ideal for systems featuring similar users or users with similar operating conditions It is recommended in structured systems in which the client has third-party systems to control the min. and max. flow rate.	- Plug&Play: provides for easy and flexible implementation as it is not supplied with options to be fitted and for quick commissioning.	Risk of over- or underflow for some of the users in the secondary circuit if they have different operating conditions (same temperature difference) A control is required by third-party equipment to ensure compliance with the unit flow limits.
FLOWZER VPS with TD-based control	Ideal for systems featuring similar users or users with similar operating conditions Ideal for systems featuring a primary and a secondary circuits physically divided from the heat exchanger or a tank with multiple connections.	- Plug&Play: provides for easy and flexible implementation as it is not supplied with options to be fitted and for quick commissioning.	Risk of over- or underflow for some of the users in the secondary circuit if their temperature difference is not the same due to the existing operating conditions

FLOWZER VPS

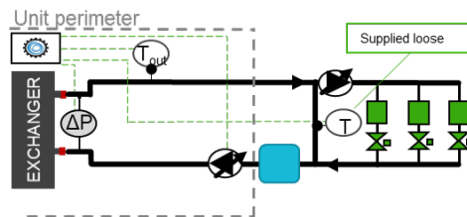

FLOWZER VDT

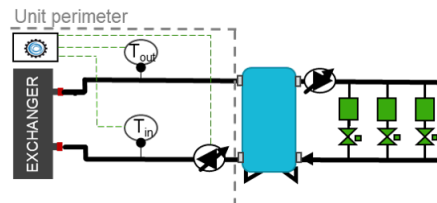

FLOWZER VDT

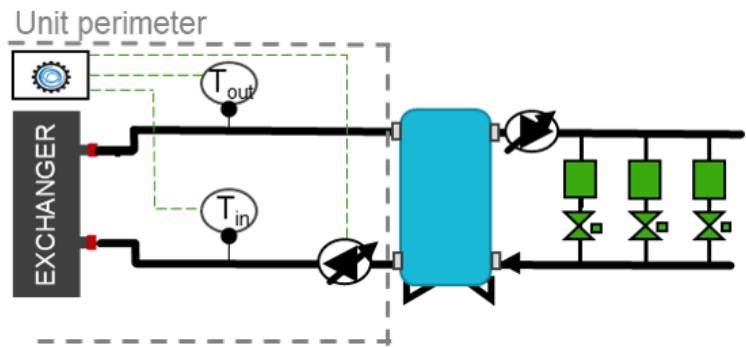

FLOWZER VPS with DT-based control

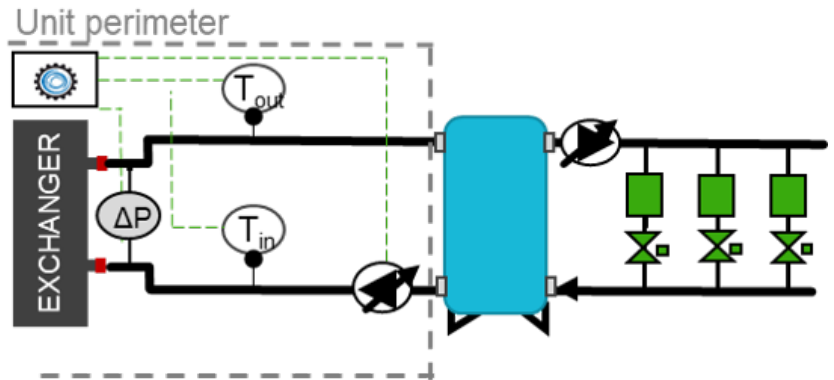

FLOWZER VPS with DT-based control

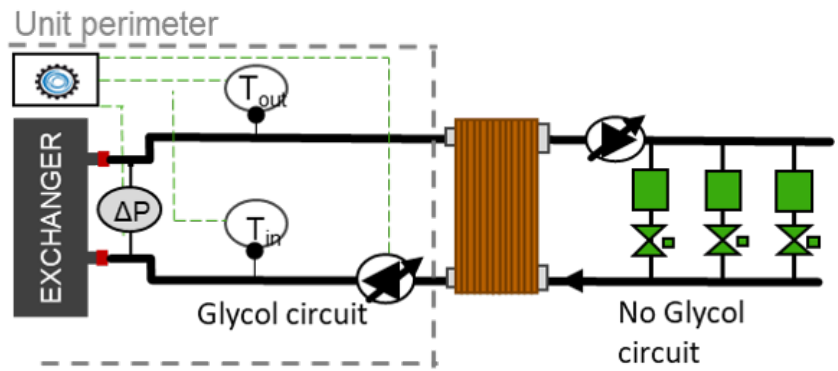

Variable flow system featuring primary circuit only			
	Application	Advantages	Disadvantages
Flowzer VFPP	Ideal for new systems intended to reduce installation costs	- Energy saving: the energy consumption during pumping operations can be cut down to 50% if compared with a traditional system Lower CAPEX thanks to reduced installation costs and smaller number of components (one pump less)	Requires some testing to correctly set the pressure available in the system and to correctly position the two transducers, based on the system layout and devices.
Flowzer VD	Ideal for systems fitted with changing users according to the season. Ideal for industrial processes, such as injection moulding, in order for each terminal to operate with the correct discharge head. It is recommended in structured systems in which the client has third-party systems to control the min. and max. flow rate.	- Plug&Play: provides for easy and flexible implementation as it is not supplied with options to be fitted therefore allows for quick commissioning.	A control is required by third-party equipment to ensure compliance with the unit flow limits.

Flowzer VFPP

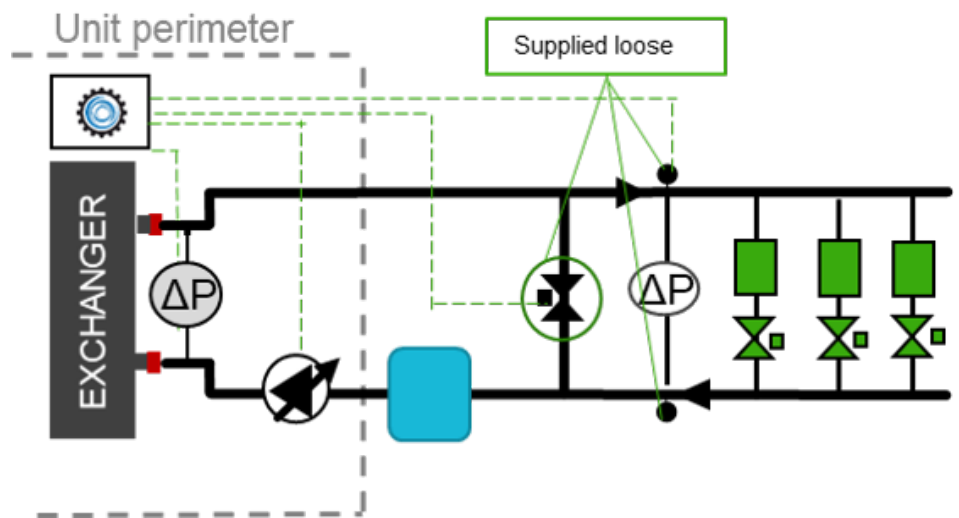

Flowzer VD

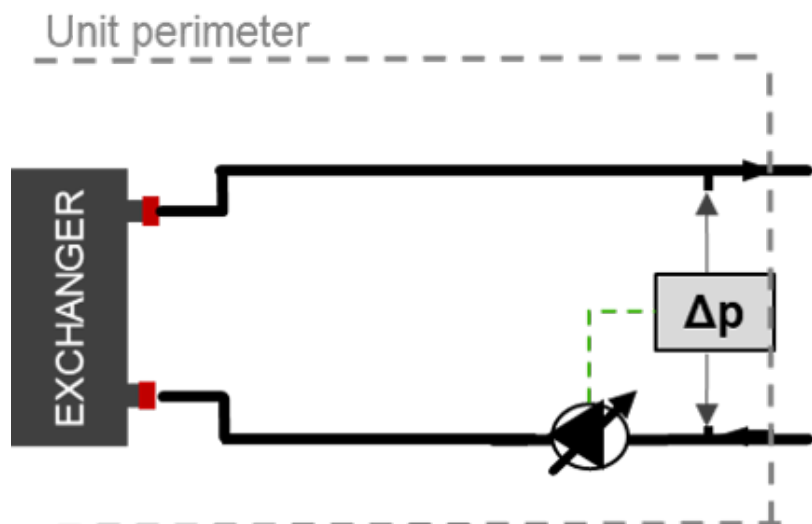

FVP FLOWZER VP - Inverter for manual pump adjustment

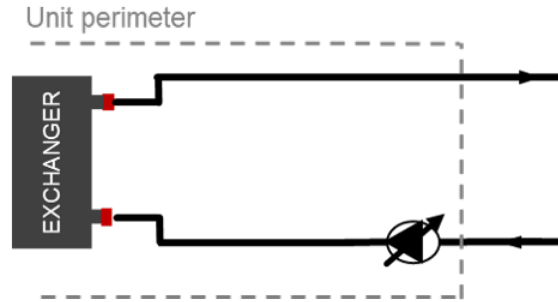

The accessory consists of inserting an inverter in the machine to manually adjust the speed of the pump (or pumps) in order to calibrate the pump flow rate on the head losses of the system.

This accessory is to be combined with one of the integrated hydraulic modules that can be selected for the unit. Units equipped with integrated hydraulic module allow a certain level of available discharge head (point A) to be obtained under nominal flow rate conditions Q_d .

But the actual head loss level of the system (e.g. characteristic curve R') normally causes the pump to find a different equilibrium point (point B), with a flow rate Q_r higher than Q_d .

In this condition, in addition to having a different flow from the nominal one (therefore also a different temperature jump), there is also a greater absorption of electric power from the pump itself.

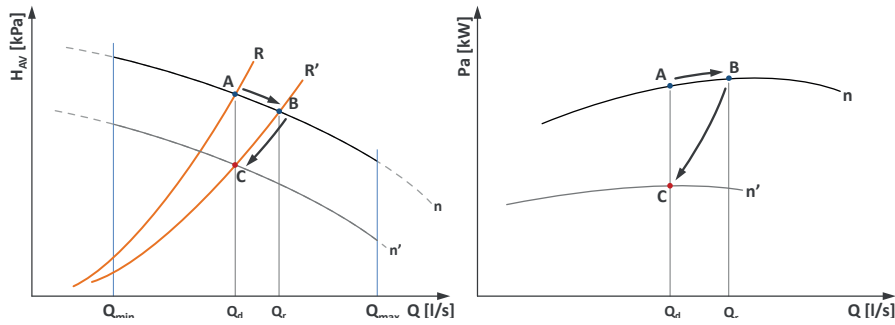

The use of the Flowzer allows the pump speed to be set manually (e.g. at speed n' instead of n) to obtain the design water flow rate and thermal gradient (point C). Once the adjustment procedure has been carried out, the pump will always work at a fixed flow rate.

The adoption of the VP Flowzer allows to considerably reduce the electrical power consumption of the pump with a consequent energy saving. By way of example, a reduction in the flow rate of 10% leads to a reduction in power consumption of around 27%.

For the freecooling units the Flowzer VP is able to manage two different speeds of the pump automatically compensating the pressure drops of the water coil.

FVD FLOWZER VD - control of available pump discharge head for variable flow systems without monitoring the flow rate limits;

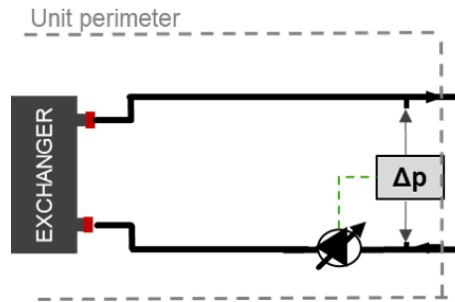

Flowzer VD requires two pressure transducers to be installed in the machine. Through these transducers, the inverter can gauge the actual pressure at the ends of the system and it can automatically adapt the pump speed to obtain a set available discharge head value. Flowzer VD must be combined with Flowzer VP. This accessory therefore allows a constant pressure system to be achieved.

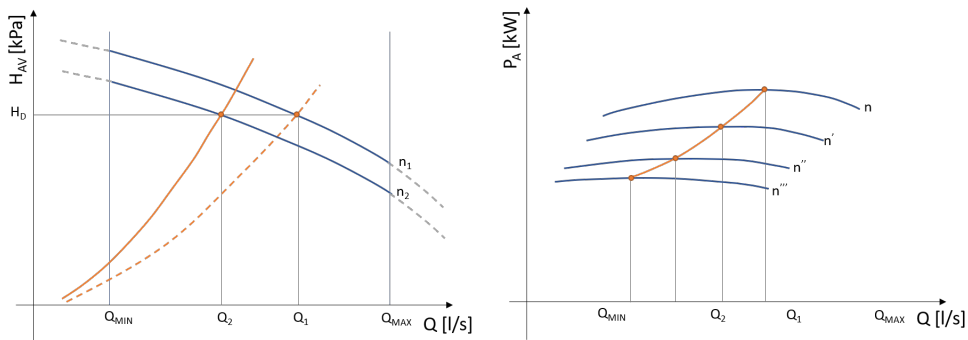

With the Flowzer VD, the customer can set, directly on the display, the available discharge head value (H_d) that the unit must maintain. As can be seen from the graph as the user request decreases, the resistant curve of the plant moves to the left, consequently the inverter reduces the speed of the pump in order to maintain the useful head necessary for the unit. With this system a significant reduction in electrical power is achieved. The customer will have to check that, in minimum flow rate conditions (that is, with the maximum number of user points closed), this is always higher than or equal to the minimum flow rate allowed by the unit.

This accessory is useful when the total head losses of the circuit are slightly variable or when they change depending on the seasons (for example, some user points are active only during summer operation and not during winter operation).

The use of this accessory also allows the pump speed to be adapted to possible fouling of the filter on the hydraulic circuit.

The option is not compatible with the Multilogic version. Please refer to the HYZER solutions for the compatibility between variable flow systems and multi-machine systems.

FVDE FLOWZER VDE - flow rate control to keep the flow rate constant as the external working conditions of the system change;

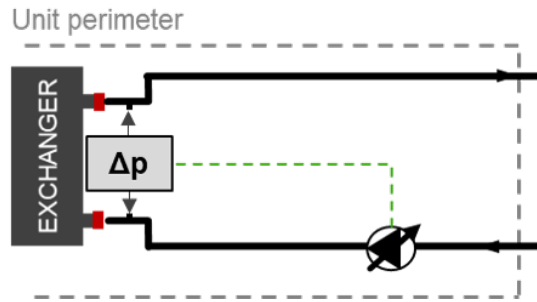

Flowzer VDE requires a differential pressure transducer to be installed in the machine. Through this transducer, the inverter can gauge the actual pressure at the ends of the heat exchanger installed in the machine and it can automatically adapt the pump speed for a constant flow value under all conditions. Flowzer VDE must be combined with Flowzer VP.

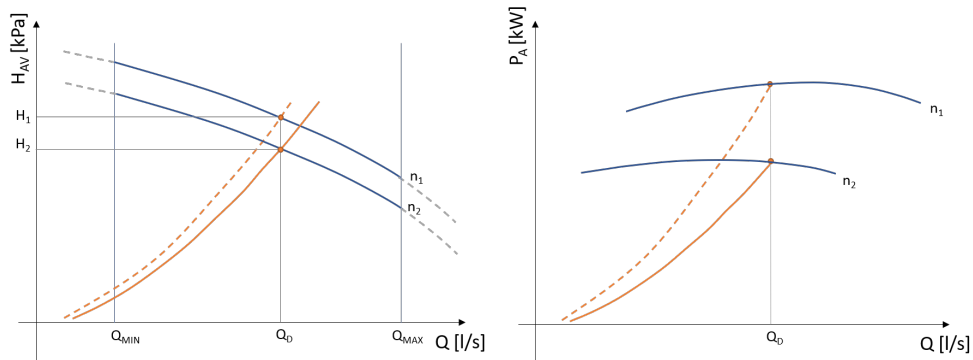

Flowzer VDE is used to automatically adjust the pump speed. As the graph shows, the inverter trips and increases the pump speed if a different condition occurs which would cause an undesired drop in the flow rate (e.g. operation of an external dry cooler). This is a more accurate solution than the VP option alone as it always provides for the water flow (Q_d) required by the design conditions.

FVDT FLOWZER VDT - flow rate control with constant TD (difference between input and output temperature in the heat exchanger on the user side) in variable flow pumps, without monitoring the flow rate limits;

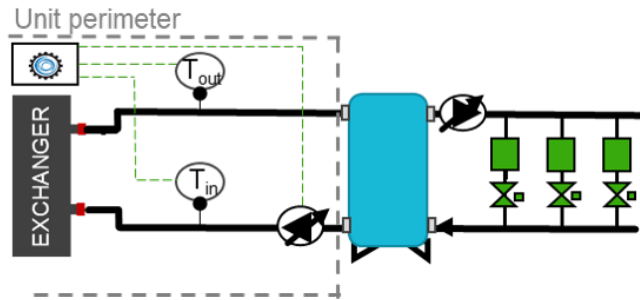

Flowzer VDT uses the temperature sensors installed at the inlet and outlet of the heat exchanger to automatically adjust the pump speed, thus keeping the T delta difference setpoint constant.

The option is not compatible with the Multilogic version. Please refer to the HYZER solutions for the compatibility between variable flow systems and multi-machine systems.

The unit must include the advanced Bluethink controller and just one heat exchanger on the user side.

With the Flowzer VDT, the customer can set, directly on the display, the available delta T value that the unit must maintain. The customer will have to check that, in minimum flow rate conditions (that is, with the maximum number of user points closed), this is always higher than or equal to the minimum flow rate allowed by the unit.

This option is specifically designed for systems in which the system users have similar operating conditions (same temperature difference).

FVF FLOWZER VFPP - automatic management of variable flow rate in systems with one single primary circuit and a bypass valve;

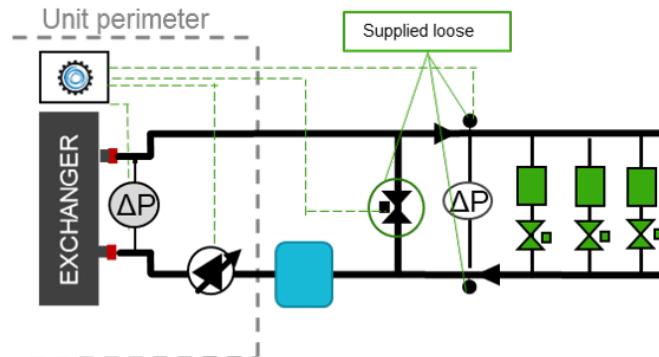

Bluethink solution for a variable flow rate system, consisting solely of a user-side primary circuit.

Flowzer VFPP includes:

- a pressure transducer installed at the ends of the user-side exchanger (Δp_e)
- a dedicated control system, installed at the factory in the electrical control panel of the unit (S_c)
- a modulating bypass valve with servo-motor supplied separately with it (V_{bp}), supplied loose (installation by the customer)
- two system pressure transducers (Δp_p) supplied separately (installation by the customer)

It is obligatory for the option to be combined with the Flowzer VP (inverter) and with one of the hydraulic modules that can be selected for the unit. The accessory is not compatible with Multilogic. Please contact our sales department for further details.

The unit must include the advanced Bluethink controller, just one heat exchanger on the user side and a minimum capacity step of 25% or less.

The option offers a complete default package to guarantee simple selection, purchasing and commissioning.

Flowzer VFPP has the advantage of:

- implementing an innovative design, which is alternative to the classic system based on fixed flow-rate primary circuit plus secondary circuit
- being ideal for new or entirely redesigned systems, especially for comfort applications
- having a variable flow system, with maximum energy saving
- simplifying the layout of the user circuit
- limiting the capex of the system
- performing a reliable check

The Flowzer VFPP system controller uses an advanced algorithm that enables prevention of unnecessary waste of energy and hunting by the inverter and the bypass valve.

The capex of the system is also reduced thanks to:

- single inverter + pumping module, integrated in the unit
- small internal footprint, due to the simplified layout

The operating principle can be summarized as follows:

- Flowzer VFPP carries out constant control of the discharge head
- the controller modulates the pump speed according to the signal detected by the system transducers Δp_p
- as the demand from the system goes down, the pump speed will be reduced.
- the pump speed can be reduced until it reaches the minimum allowed flow rate on the heat exchanger of the unit
- this flow rate is indirectly monitored through the losses detected by the differential pressure transducer Δp_e
- When the minimum allowed flow rate threshold is exceeded, the control system will open the bypass valve V_{bp} to recirculate the flow rate that is not required by the system, but is necessary to guarantee the minimum flow rate to the heat exchanger.

In the required minimum load condition (that is, with all system terminals switched off) the necessary minimum volume (V_{min}) must be ensured by the relevant tank to be installed between the unit and the separator or the bypass pipe.

The bypass valve V_{bp} is controlled through a 0-10 V signal and must therefore be installed within 30 m of the unit.

The pressure transducers of the system Δp_p provide a 4-20 mA signal and require two 1/4" female fittings. These transducers must be installed within 200 m of the unit, near the system terminal that is affected by the highest line head losses or in any case in a position where it is possible to measure an adequate pressure value.

Further details can be found in the relevant manual.

FVPS FLOWZER VPS - automatic management of variable flow rate, including balancing of flow rates between primary and secondary circuits;

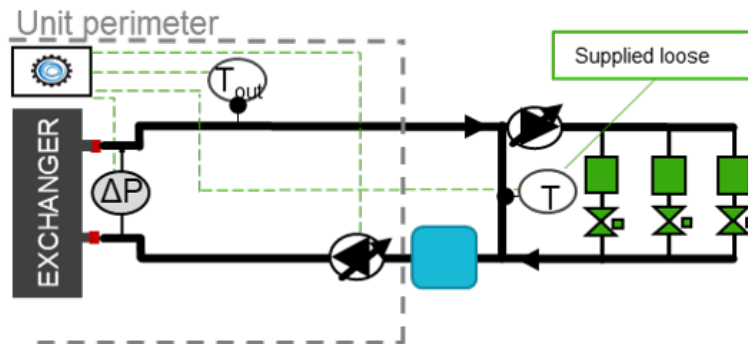

Bluethink solution for a variable flow rate system, consisting of a primary circuit plus secondary circuit. It is obligatory for the option to be combined with the Flowzer VP (inverter) and with one of the hydraulic modules that can be selected for the unit. The accessory is not compatible with Multilogic. Please contact our sales department for further details.

The unit must include the advanced Bluethink controller, just one heat exchanger on the user side and a minimum capacity step of 25% or less.

The option offers a complete default package to guarantee simple selection, purchasing and commissioning. Flowzer VPS has the advantage of:

- being ideal for renovations of existing systems, especially for comfort applications
- achieving a complete variable flow system, with maximum energy saving
- implementing a flexible design, e.g. for scalable or multi-zone systems

The maximum energy saving is achieved thanks to the advanced algorithm, which prevents hunting by the inverter and balances the pump speed and the recirculation flow rate to a minimum.

With refurbishments, the system's capex is limited to the unit and its commissioning.

The dimensions of the inverter of the unit and of the pump module can be favoured by the low design discharge head of the primary circuit.

The operating principle can be summarized as follows:

- Flowzer VPS performs a smart check of the flow rate in the primary circuit and balances it with the flow rate in the secondary circuit.
 - the system controller modulates the pump speed according to the condition detected by the system sensors T
 - if the system terminals are switched off, the flow rate of the secondary circuit will decrease; therefore the direction of flow is detected indirectly as temperature difference by the system sensors through the separator or the bypass pipe
 - The check thus contributes to reducing the speed of the primary pump until the min. flow threshold in the heat exchanger of the unit is exceeded.
 - this flow rate is indirectly monitored through the losses detected by the differential pressure transducer Δp_e
- In the required minimum load condition (that is, with all system terminals switched off) the necessary minimum volume (V_{min}) must be ensured by the relevant tank to be installed between the separator or the bypass pipe.

The temperature sensors of the system T provide a 4-20 mA signal and require 1/2" female fittings.

Further details can be found in the relevant manual.

FVPD FLOWZER VPS with TD-based control - automatic management of the variable flow rate, including control with constant temperature difference (TD) in the heat exchanger on the user side in systems featuring both the primary and secondary circuits.

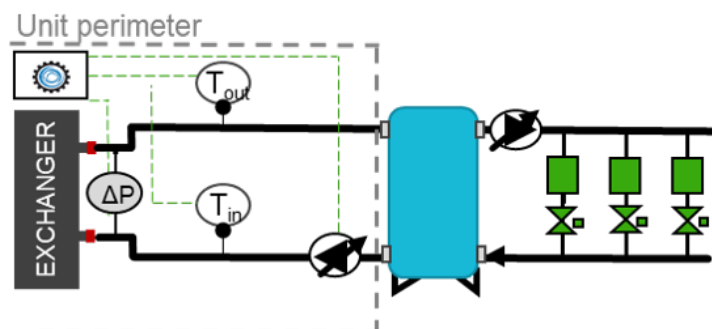

Bluethink solution for variable flow systems - ideal for systems featuring a primary and a secondary circuit physically divided by a heat exchanger or a tank with multiple connections.

flowzer vps with TD-based control includes:

- a differential pressure transducer, installed at the factory at the ends of the user-side heat exchanger of the unit (Δp_e)

The option must be necessarily combined with the Flowzer VP (inverter) and with one of the hydraulic modules that can be selected for the unit. The option is not compatible with the Multilogic version. Please refer to the HYZER solutions for the compatibility between variable flow systems and multi-machine systems.

The unit must include the advanced Bluethink controller and just one heat exchanger on the user side.

The option offers a complete default package to guarantee simple selection, purchasing and commissioning.

flowzer vps with TD-based control offers the following advantages:

- a full package that is easy to install as all the regulating devices are pre-assembled and pre-wired in the unit;
- achieving a complete variable flow system, with maximum energy saving
- the ideal solution to refurbish existing systems where the T different must be kept constant in the system, especially in comfort applications;

The maximum energy saving is achieved thanks to the advanced algorithm, which prevents hunting by the inverter and balances the pump speed and the recirculation flow rate to a minimum.

The dimensions of the inverter of the unit and of the pump module can be favoured by the low design discharge head of the primary circuit.

The operating principle can be summarized as follows:

- flowzer vps with TD-based control performs smart monitoring of the flow rate in the primary circuit, keeping the T difference constant in the heat exchanger;
- the system controller modulates the pump speed according to the condition detected by the temperature sensors (T) in the system, which are installed at the inlet and outlet of the heat exchanger on the user side;
- the difference in the water temperature (T) and flow rate are inversely proportional, which is why if the T difference is reduced at the same performance level, the water flow exceeds the flow required by the system and the pump speed is reduced in order to save energy;

on the other hand, when the load increases, the T difference increases in the system and the pump speed is increased accordingly.

- The check contributes to reducing/increasing the speed of the pump in the primary circuit until the min./max. flow threshold admitted in the heat exchanger of the unit is exceeded.
- this flow rate is indirectly monitored through the losses detected by the differential pressure transducer Δp_e

The temperature sensors of the system output a 4-20 mA signal.

Further details can be found in the relevant manual.

HFx HYZER E VFPP function

The HYZER E VFPP function combines the Multilogic function, which is designed to manage multi-machine systems, with the FLOWZER VFPP control for variable flow systems.

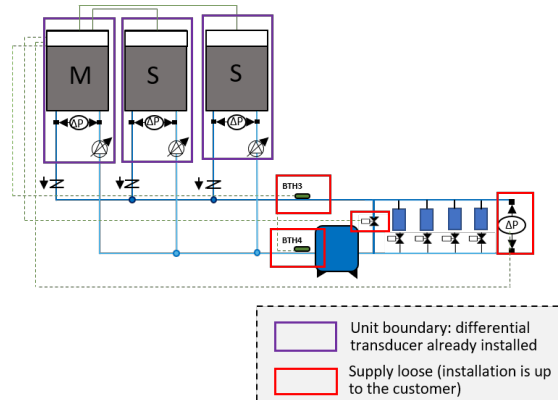

It is obligatory for the option to be combined with the Flowzer VP (inverter) and with one of the hydraulic modules that can be selected for the unit.

Units operate according to the Master/Slave logic that is typical of a Multilogic system. For additional details, please refer to the FMx option.

VFPP control requires the installation on the machine of a differential transducer at the ends of the user-side heat exchanger in order to keep the flow rate in the system within a specific min. value allowed.

For additional details on the FLOWZER VFPP logic, please refer to the dedicated FVF option.

The networked units may be of different types, and the same observations as for the Multilogic option apply:

- if there are both chiller units and heat pumps in the network, the Master unit must obligatorily be one of the HP units;
- if there are both free-cooling and non free-cooling units in the network, the Master unit must obligatorily be one of the free-cooling units.

The HYZER E function requested with the unit can be:

- **HF0:** HYZER E VFPP function for Slave units;
- **HF2:** HYZER E VFPP function for the Master unit in order to manage up to 2 Slave units;
- **HF6:** HYZER E VFPP function for the Master unit in order to manage up to 6 Slave units.

If you need to connect more than 6 slaves (up to 31), you can ask for a quotation from our sales department.

For the slave units, the accessory includes:

- programming of the unit as slave of a system of machines in Multilogic network

For the master units, the accessory includes:

- programming of the unit as master of a system of machines in Multilogic network
- entering of the parameters necessary for connection with the individual slave units
- installation in the electrical control panel of a network switch to allow the units to be connected in a LAN network.
- the supply of 2 temperature probes to be positioned on the delivery and return manifold for system thermoregulation (supplied with the system - installation and wiring by the customer);
- the supply of two pressure transducers (supplied with the system - installation and wiring by the customer) to be installed near the system terminal that is affected by the highest head losses in the line or in any case in a position where it is possible to measure an adequate pressure value.
- The option also includes the supply of a bypass valve controlled by a 0-10 V signal, which must be selected in function of the system capacity. Please refer to the VBx options for correct selection.

The connection between the master unit and the slave units made with a CAT cable. 5E/UTP (prepared by the customer) with RJ45 connectors. Maximum cable length 100m.

For further details, please refer to the controller manual.

VBx VFPP bypass valve for HYZER E

The option is supplied with the bypass valve, which is selected according to the system capacity.

This option must be selected with either the "HYZER E VFPP function for Master unit to manage up to 2 Slave units" or "HYZER E VFPP function for Master unit to manage up to 6 Slave units".

	System capacity range**	Quantity	Diameter	Qmax**
	kW	-	in	m ³ /h
S_A	<240	1	2 1/2"	41.3
S_B	240÷335	1	3"	57.6
S_C	335÷570	1	4"	98
S_D	570÷850	1	5"	146.2
S_E	850÷1250	1	6"	215
S_F	1250÷1700	2	2 x 5"	2 x 146.2
S_G	1700÷2500	2	2 x 6"	2 x 215

** values based on a 5 °C temperature difference between the delivery and the return temperature

HSx HYZER E VPS function

The HYZER E VPS function combines the Multilogic function, which is used to manage multi-machine systems, with the FLOWZER VPS control for variable flow systems.

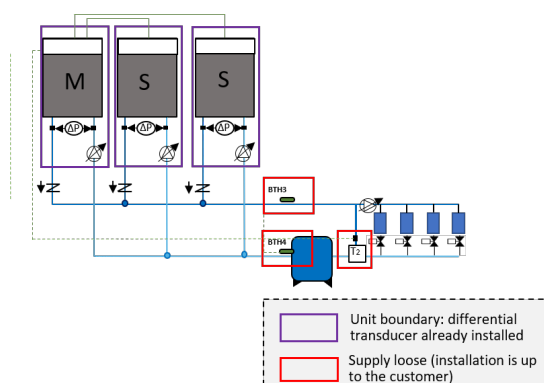

It is obligatory for the option to be combined with the Flowzer VP (inverter) and with one of the hydraulic modules that can be selected for the unit.

Units operate according to the Master/Slave logic that is typical of a Multilogic system. For additional details, please refer to the FMx option.

VPS control requires the installation on the machine of a differential transducer at the ends of the user-side heat exchanger in order to keep the flow rate in the system within a specific min. value allowed.

For additional details on the FLOWZER VPS logic, please refer to the dedicated FVPS option.

The networked units may be of different types, and the same observations as for the Multilogic option apply:

- if there are both chiller units and heat pumps in the network, the Master unit must obligatorily be one of the HP units;
- if there are both free-cooling and non free-cooling units in the network, the Master unit must obligatorily be one of the free-cooling units.

The HYZER E function requested with the unit can be:

- **HS0:** HYZER E VPS function for Slave units;
- **HS2:** HYZER E VPS function for the Master unit in order to manage up to 2 Slave units;
- **HS6:** HYZER E VPS function for the Master unit in order to manage up to 6 Slave units.

If you need to connect more than 6 slaves (up to 31), you can ask for a quotation from our sales department.

For the slave units, the accessory includes:

- programming of the unit as slave of a system of machines in Multilogic network

For the master units, the accessory includes:

- programming of the unit as master of a system of machines in Multilogic network
- entering of the parameters necessary for connection with the individual slave units
- installation in the electrical control panel of a network switch to allow the units to be connected in a LAN network.
- the supply of 2 temperature probes to be installed on the delivery manifold and on the bypass branch, which are typical of VPS control (supplied with the system - installation and wiring by the customer).

The connection between the master unit and the slave units made with a CAT cable. 5E/UTP (prepared by the customer) with RJ45 connectors. Maximum cable length 100m.

For further details, please refer to the controller manual.

HDx **HYZER E VPS with DT-based control function**

The HYZER E VPS with TD-based control function combines the Multilogic function, which is used to manage multi-machine systems, with the FLOWZER VPS with DT-based control control for variable flow systems.

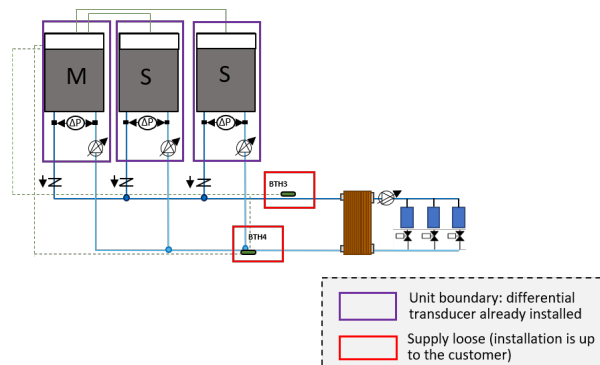

It is obligatory for the option to be combined with the Flowzer VP (inverter) and with one of the hydraulic modules that can be selected for the unit.

Units operate according to the Master/Slave logic that is typical of a Multilogic system. For additional details, please refer to the FMx option.

VPS with DT-based control control requires the installation on the machine of a differential transducer at the ends of the user-side heat exchanger in order to keep the flow rate in the system within a specific min. value allowed.

For additional details on the FLOWZER VPS with TD-based control logic, please refer to the dedicated FVPS with DT-based control option.

The networked units may be of different types, and the same observations as for the Multilogic option apply:

- if there are both chiller units and heat pumps in the network, the Master unit must obligatorily be one of the HP units;
- if there are both free-cooling and non free-cooling units in the network, the Master unit must obligatorily be one of the free-cooling units.

The HYZER E function requested with the unit can be:

- **HD0:** HYZER E VPS with TD-based control function for Slave units;
- **HD2:** HYZER E VPS with TD-based control function for the Master unit in order to manage up to 2 Slave units;
- **HD6:** HYZER E VPS with TD-based control function for the Master unit in order to manage up to 6 Slave units.

If you need to connect more than 6 slaves (up to 31), you can ask for a quotation from our sales department.

For the slave units, the accessory includes:

- programming of the unit as slave of a system of machines in Multilogic network

For the master units, the accessory includes:

- programming of the unit as master of a system of machines in Multilogic network
- entering of the parameters necessary for connection with the individual slave units
- installation in the electrical control panel of a network switch to allow the units to be connected in a LAN network.

The connection between the master unit and the slave units made with a CAT cable. 5E/UTP (prepared by the customer) with RJ45 connectors. Maximum cable length 100m.

For further details, please refer to the controller manual.

PVX Variable flow setup for HYZER X

The dedicated HYZER X controller is designed to manage the different units, devices and components that make up a hydronic system.

Systems featuring this controller require that the PVX option be installed at the ends of the user-side heat exchanger of a differential pressure transducer so that the machine is set up for variable flow rate control.

This option is mandatory in all units making up the system.

For additional information on the product HYZER X, please refer to the specific technical catalogue.

VIX Shut-off valves for systems with external pumps for HYZER X

Systems featuring the HYZER X controller enable the selection of the shut-off valve used in systems that have an external pumping unit.

The option is always supplied separately from the unit and is for installation by the customer.

FLMX User-side flow meter for HYZER X

Systems featuring the HYZER X controller enable the selection of the flow meter option to calculate the flow rate and the performances of the units.

The option is supplied with the system for installation on the user side (installation by customer).

SID Hydraulically disconnected tank

The tank fitted in the unit will have an inlet and outlet, flush with the machine profile, and will be disconnected from the remaining hydraulic circuit. This will allow correct enabling of the 3-way valve for domestic hot water management, thus avoiding going through the buffer tank during domestic hot water production.

V3MC 3-way modulating valve on hot circuit

The accessory involves the supply of a 3-way modulating valve to be inserted on the hot circuit in order to check that the temperature of the water entering the exchanger is always higher than the minimum allowed.

Electrical accessories

CSP Set point compensation depending on external air temperature

For units fitted with this accessory, the set point of the unit is set so that it can vary between two values, a maximum and a minimum, depending on the external air temperature. The compensation ramp and the maximum and minimum values of the set point can be changed by the user.

Unless otherwise specified in the order, the controller will be set to implement a positive compensation logic according to the temperatures shown in the following diagrams:

If the difference between the minimum set point and the maximum set point is greater than 5K, it is compulsory to ask for the accessory "Electronic expansion valve".

Chiller

Negative compensation

Chiller

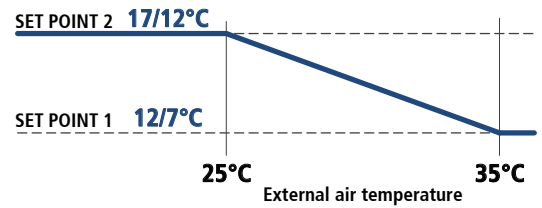
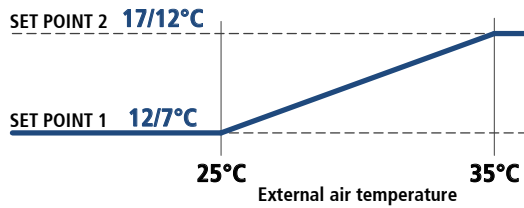

Heat pump

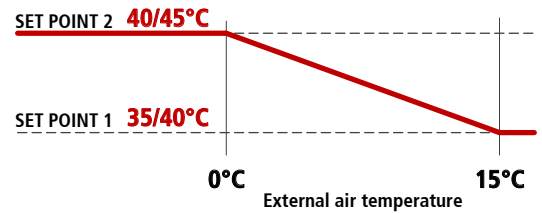
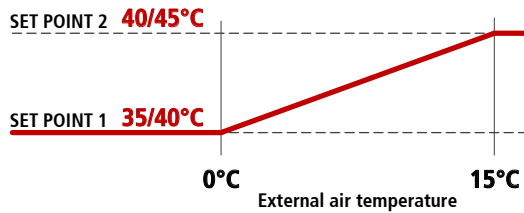

CP Single potential free operating contacts

For units fitted with this accessory, there are clean contacts available on the terminal board inside the electrical box from which the customer can acquire signals that show the status of the unit's components (compressors, fans, pumps, alarms).

TERM Remote-controlled user terminal panel

This accessory allows the terminal normally situated on the machine to be replicated on a support situated at a distance. It is particularly suitable when the unit is placed in an area that is not easily accessible.

The accessory is supplied loose and is to be installed by the customer at a maximum distance of 120m from the unit.

RMMT Maximum and minimum voltage relay

This accessory constantly monitors the voltage value and the unit's power supply phase sequence. If the supply voltage does not fall within the set parameters or there is a phase reversal, an alarm is generated that stops the machine to prevent damage to its main parts

SETD Double set point from digital input

The accessory allows you to preset two different operating set points and manage the change from one to the other through a digital signal.

The set point temperatures must be specified when ordering. For optimization of the unit, reference will be made to the lower set point in chiller mode and the higher set point in heat pump mode.

Unless otherwise specified in the order, the controller will be set at the factory with the following temperatures:

- in chiller mode, set point 1 to 7°C and set point 2 to 12°C
- in heat pump mode (only for HP units) set point 1 to 45°C and set point 2 to 40°C

For operating conditions other than standard, unless otherwise specified in the order for the second set point, the controller will be set at the factory:

- by adding 5°C to the main cooling set point
- by subtracting 5°C from the main heating set point

If necessary this value will however be limited to remain within the operating limits of the unit.

AS Automatic management of domestic hot water

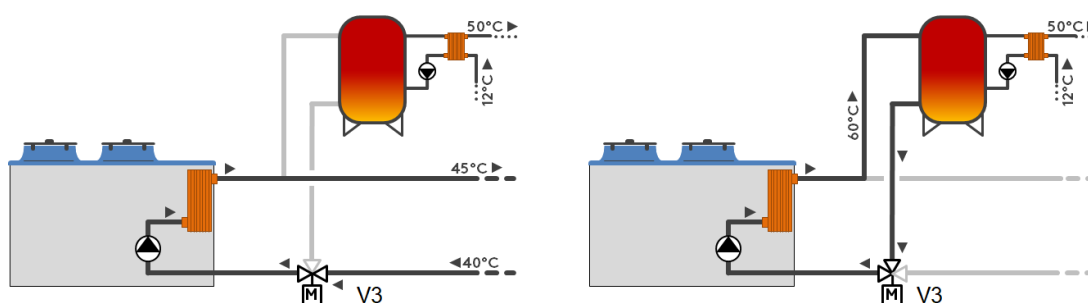

This function enables the unit to control the temperature inside a domestic hot water storage tank and to manage a 3-way valve outside the unit (available as an accessory).

The water temperature in the domestic hot water tank is controlled through a dedicated probe situated in the tank.

Normally, the heat pump operates on the system to meet the comfort requirements of the building, but when the water temperature in the domestic hot water tank falls below a set threshold, the controller switches to domestic hot water production.

If the unit is operating as heat pump for heating, the 3-way valve will be switched and the set point changed. On the other hand, if the unit is producing chilled water for air conditioning, the controller switches the unit to heat pump mode, gives it the set point for domestic hot water and turns the 3-way valve to the appropriate position. Once the temperature in the domestic hot water tank has reached the set value, the unit automatically returns to producing water for the heating or air conditioning system.

When there is a defrost request, the 3-way valve is always forced to position itself on the system, whatever operating mode it may be in.

Domestic hot water production is always given priority.

With this accessory there are two digital inputs in the electrical control panel for respectively deactivating domestic hot water production and the production of water for the heating/air conditioning system.

When the unit is working in "domestic hot water only" mode, the pump is normally off and is switched on only for the time required to meet the demand for domestic hot water production.

When this accessory is fitted, the machine must have control of pump operation. This means that either the unit is equipped with one of the hydronic modules available in the catalogue (therefore with at least one pump installed on it) or the relay for external pump management must be requested as accessory.

The probe to be fitted in the domestic hot water tank is supplied with the unit with a 5m long cable. The probe is used to measure the water temperature in the hottest part of the tank, so it must be positioned in a specially prepared pocket and secured using heat conducting paste. Installation by the customer.

In case of management with variable water flow, the installation must necessarily be made with the derivation towards the domestic hot water tank upstream of any bypass valve or channel.

RE1P Relay for management of 1 external pump

This accessory can be requested for units without pumps and allows a pump outside the machine to be controlled.

RE2P Relay for management of 2 external pumps

This accessory can be requested for units without pumps and allows two pumps outside the machine to be controlled with a running/stand-by logic by implementing a rotation on the hours of operation.

The two pumps are controlled by two separate relays.

IACV Automatic circuit breakers

With this accessory, automatic circuit breakers are installed instead of fuses for the protection of auxiliary loads. Also, the same accessory uses automatic circuit breakers with adjustable thermal overload protection to protect the compressors.

LIID Limitation of the current absorbed by digital input

When this accessory is requested, a digital input is prepared in the terminal board to activate the forced capacity reduction of the unit to a set fixed level.

This accessory is useful when there is a need to necessarily limit the power absorbed by the unit as regards particular conditions.

We point out that, in some conditions (for example, during defrosting, oil return cycles or hourly compressor rotation procedures), the controller could force the unit to operate at full capacity for limited periods of time.

CSU Enabling for integration heater on user side

The accessory enables management of a heat source outside the unit which is supplementary to the user circuit.

The necessary OK signals for controlling a maximum of four capacity steps are included in the electrical control panel. Activation of the steps takes place depending on the distance from the set heat pump set point.

CSS Enabling for integration heater on tap water side

The accessory enables management of a heat source outside the unit which is supplementary to the domestic hot water circuit.

TSS Thermoregulation from tank-mounted probe

This option is designed to start thermoregulation of the unit, based on the set point of an additional probe that can be installed in the storage tank.

The probe is 6 metre long and is supplied together with the unit.

GIT Zone management for mixed heating plants

This option is designed to set the water supply temperature through the regulation of a 3-way valve for each area. This option can control up to 2 areas with different temperature set points (e.g. a mixed installation with radiators and fan coils).

This option includes an energy saving function that is intended to optimise the operating set point of the unit based on the actual demand of each area.

This option includes two 6-metre long probes that are supplied together with the units.

SETV Variable set point with remote signal

The accessory allows the set point to be varied continuously between two preset values, a maximum and a minimum, depending on an external signal that can be of the 0-1V, 0-10V or 4-20mA type.

The set point temperatures and the type of signal to use for the adjustment must be specified when ordering. For optimization of the unit, reference will be made to the lower set point in chiller mode and the higher set point in heat pump mode.

Unless otherwise specified in the order, the controller will be set at the factory with 0-10V analogue input and with the following temperatures:

- in chiller mode, 0V will correspond to a set point of 7°C and 10V will correspond to a set point of 12°C
- in heat pump mode (only for HP units), 0V will correspond to a set point of 45°C and 10V will correspond to a set point of 40°C

For operating conditions other than standard, unless otherwise specified in the order for the variable set point, the controller will be set at the factory:

- by adding 5°C (10V) to the main cooling set point (0V)
- by subtracting 5°C (10V) from the main heating set point (0V)

If necessary this value will however be limited to remain within the operating limits of the unit.

SQE Heater for electrical control panel

Electric heaters are positioned inside the electrical control panel and these prevent the formation of ice or condensation inside it.

ARU Stopping of the unit due to temperatures below the operating limit

With this accessory, it is possible to set the unit so that the controller switches off the compressors when the unit is operating in heat pump mode and the external air temperature falls below a minimum set limit: this will prevent the unit from going into low pressure alarm, so avoiding having to manually restart the machine. When the external air temperature returns above the set threshold temperature, the unit will automatically resume operation without it being necessary to do anything.

For units equipped with integrated pump, the pump will always be kept running so as to prevent ice formation and ensure correct reading of the temperature and antifreeze safety probes at all times.

The stopping temperature must be set based on the set point temperature and in accordance with what is allowed by the operating limits of the machine.

NSS Night Shift System

In the day time slot, which is normally the one with the highest thermal load, priority is given to efficiency and therefore the machine operates with a fan regulation curve that maximizes the EER. In the night time band (or in any case from time band decided by the customer), the priority changes to limiting the noisiness of the machine and therefore the controller carries out an adjustment of the control ramp of the condensing fans, thereby reducing the air flow rate and consequently the noise emission level. So, in this time band, the unit is a super low noise machine (equivalent to SLN). In any case, if there is a need for additional cooling capacity, the controller will manage the demand, if necessary, by accelerating the fans and keeping condensation within the correct operating limits. The time slots can be set from the control depending on installation requirements.

When the unit is working in heat pump mode, in order to maximise the COP and to obtain the widest possible operating limits, the control of the unit forces the fans to the maximum speed also during the night time bands.

ENM Energy meter

The accessory allows the main electrical quantities (including voltage, current, power) to be read on the three phases, via current transformer.

This accessory communicates with the BlueThink controller to supervise the monitored data. The values measured are then made available through the unit display and the web server.

SV3 Signal for 3-way modulating valve

In the electrical control panel, a 0-10V output is preset to be used to control a 3-way modulating valve inserted on the hot circuit.

If the temperature of the water entering the hot exchanger is too low (for example, after the machine has been stopped for an extended period), through this signal, the controller of the unit will control the valve so as to recirculate part of the flow rate at the outlet and ensure that the unit always works within the operating limits. The 3-way modulating valve is not included in this accessory, but can be requested as further accessory.

ENT Energy trend

This function estimates the energy consumption and the cooling and heating production of the unit. The efficiency of the unit is calculated ("EER" for cooling operation or "COP" for heating operation).

Data are calculated in real time according to the working conditions of the unit (evaporation and condensing pressure, external air temperature).

Data are also displayed in the unit user interface in a dedicated "Energy Trend" mask.

Following data are also recorded in the logs in the controllers memory:

- "EnergyTrendHours" contains records of the values of energy absorbed and produced for each hour
- "EnergyTrendHistory" contains records of the values of energy absorbed and produced for each day

The "logs" can then be downloaded via a USB pendrive or from the WEB pages.

The function returns values within the operating envelope of the machine. No data will be recorded outside the operating envelope. The data is stored as an hourly average for 12 months of operation. After 12 months the control overwrites the first data. If hourly resolution is required, the data must be downloaded at least once a year. The control also stores daily average data. This is stored for the life of the unit. In case of microprocessor board failure, data, if not previously downloaded and saved, will be lost.

Network accessories

PBA BACnet protocol over IP (Ethernet)

The controller is set for use, in read and write mode, of the BACnet port on IP protocol.

By default, the programming gives read-only access to the control of the unit. Reading / writing access is activable on field with a service level.

PSN SNMP protocol

The accessory consists of a gateway that allows Ethernet connection to a SNMP manager supervision system.

The use of this accessory causes the RS485 serial port to be unavailable.

GLO Modbus Lonworks Gateway

With this accessory, a RS485/Lon gateway is installed inside the electrical control panel.

By default, the programming gives read-only access to the control of the unit. Reading / writing access is activable on field with a service level.

FMx Multilogic Function

The Multilogic function allows management of up to 32 units equipped with advanced Bluethink controller and connected in hydraulic parallel with each other.

Multilogic systems only operate with the "Ipro" advanced controller and if the connected units have the same software version. A Multilogic network cannot operate with different software versions/releases.

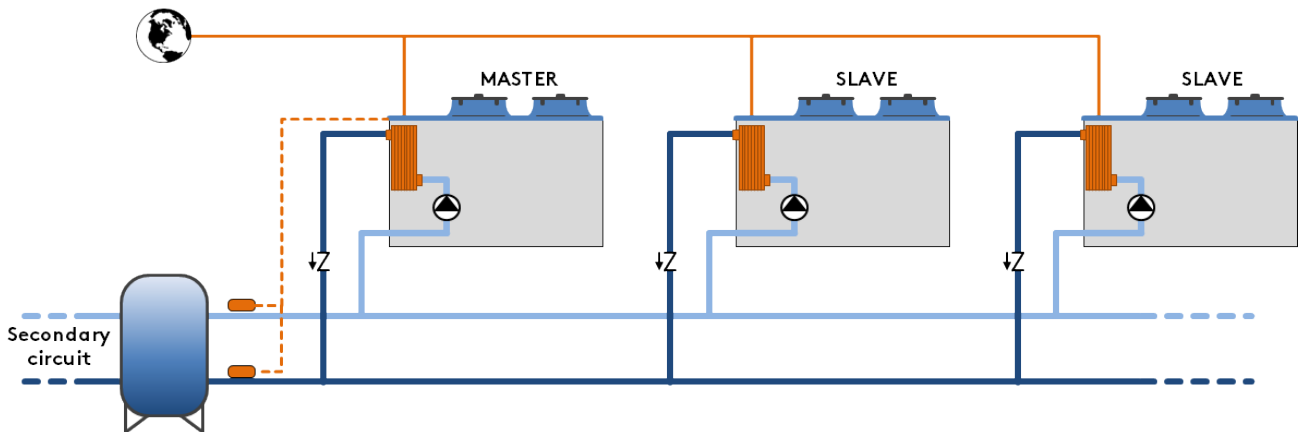

On the basis of the information recorded by the temperature probes installed on the delivery and return manifolds of the system, with the master unit, a capacity request is generated that is distributed among the units connected in the Multilogic network according to settable priority and optimization logics.

If communication between the units fails or if the master is off-line, the slave units can continue to work according to the set thermoregulation parameters.

The connected units can be different from each other, in terms of capacity and set-up, provided the following rules are complied with:

- if there are both chiller units and heat pumps in the Multilogic network, the Master unit must obligatorily be one of the HP units
- if there are both free cooling and non free-cooling units in the Multilogic network, the Master unit must obligatorily be one of the free-cooling units.

The Multilogic function that can be requested with the unit can be:

- **FM0:** Multilogic function for Slave unit
- **FM2:** Multilogic function for Master unit for managing up to 2 Slaves
- **FM6:** Multilogic function for Master unit for managing up to 6 Slaves

If you need to connect more than 6 slaves (up to 31), you can ask for a quotation from our sales department.

For the slave units, the accessory includes:

- programming of the unit as slave of a system of machines in Multilogic network

For the master units, the accessory includes:

- programming of the unit as master of a system of machines in Multilogic network
- entering of the parameters necessary for connection with the individual slave units
- installation in the electrical control panel of a network switch to allow the units to be connected in a LAN network.
- the supply of 2 temperature probes to be positioned on the delivery and return manifold of the system (supplied separately with it, installation and wiring by the customer)

The connection between the master unit and the slave units made with a CAT cable. 5E/UTP (prepared by the customer) with RJ45 connectors. Maximum cable length 100m.

For further details, please refer to the controller manual.

SMAR Smartlink function predisposition

This accessory makes it possible to connect the controller of the unit with the controller of a Swegon GOLD™ air handling unit via a simple serial cable, so allowing their operating logics to be merged into a single consciousness that pursues the maximum energy efficiency of the system. The RS485 serial interface is already included and dedicated to connection with Swegon units.

The option is incompatible with:

- double set point
- variable set point with remote signal
- summer/winter selection by digital input
- set point compensation depending on external air temperature
- multilogic
- all communication protocols.

SMAP Setup of Smartlink+ functions

This option is used to connect the controller in the unit with the controller of a Swegon GOLD™ air handling unit via the Ethernet port TCP/IP, so allowing the operating logics of hydronic and ventilation systems to be merged into a single logic for the achievement of maximum energy efficiency and comfort. This option is only available for units featuring an advanced controller and it is compatible with Multilogic and Hyzer systems only if the machine is the Master.

The option is incompatible with:

- double set point
- variable set point with remote signal
- set point compensation depending on external air temperature
- all communication protocols.

BEET Blueye® via Ethernet

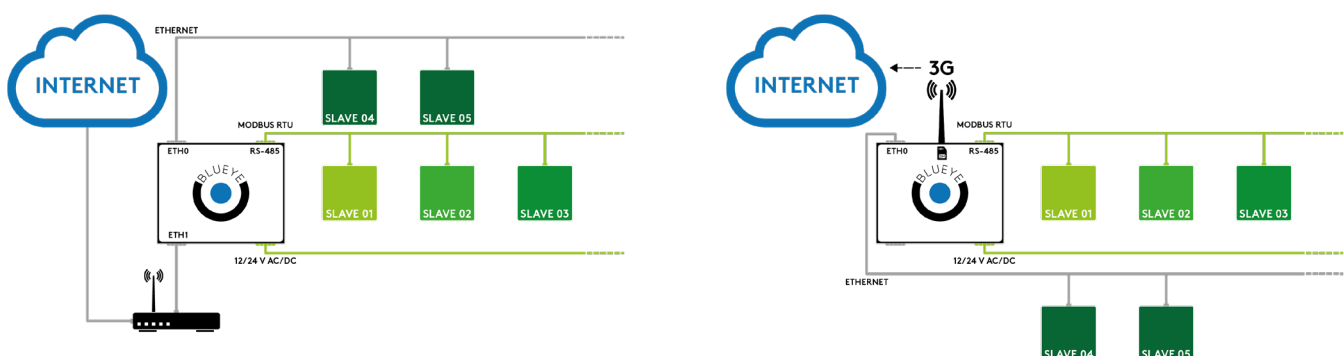

Blueye® is a supervision platform that enables remote monitoring of one or more units in the same system interconnected through a network with Modbus protocol.

This accessory features the Blueye device, as already installed and wired in the unit.

The critical variables to be monitored over time are identified for each connected device. These variables are sampled and saved to the cloud so that they are accessible at all times through a web portal or a mobile APP (available for Android and iOS).

The following options can be selected for connection to the internet:

- a LAN (Ethernet) connection - available in the system;
- a connection to a mobile network - at least 3G. The data SIM card is not included.

Three different types of contracts can be signed.

Blueye® Cloud Basic:

- to monitor a max. of 20 variables in total over max. 5 units/peripherals;
- to set a min. sampling frequency of 60 seconds.

Blueye® Cloud Advanced:

- to monitor a max. of 200 variables in total over max. 10 units/peripherals;
- to set a min. sampling frequency of 5 seconds.

Blueye® Connect:

- To monitor up to 10 units/peripherals.

Subscribing to any of the **Blueye® Cloud** enables:

- viewing the history of the monitored variables, in the form of both numerical values and graphs;
- downloading the history of variables in CSV format;
- the creation of automatic reports;
- setting notifications (via APP or mail) with settable thresholds for each variable;
- switching the unit ON/OFF remotely;;
- changing the set point remotely;
- selection of SUMMER/WINTER mode remotely (for reversible units only).

The subscription to the **Blueye® Connect** service offers the advantages below:

- a safe connection (tunnelling) between the user and the remote unit through the Blueye® portal;
- full access to the remote controller;
- real time monitoring;
- software upgrading.

Blueye® via Ethernet is only available for units supplied with an advanced controller and does not include any type of service. This service must be purchased separately based on the number of units/devices to be connected and the number of variables to be monitored. In order to connect multiple units to **Blueye® device, the network switch is required (this accessory is sold separately).**

Units can also be connected to the Blueye device through the RS485 network featuring a Modbus RTU protocol (for this option, refer to BERS accessory).

For further details, refer to the specific Blueye® documentation.

SW4P Network switch with 4 ports

The accessory includes installation in DIN rail of a professional 4-port network switch.Requires Blueye via Ethernet.

Other accessories

SCK Snow protection kit

Painted sheet metal preventing the build-up of snow on the heat exchanger on the source side. The option is always supplied separately from the unit and is for installation by the customer.

AG Rubber anti-vibration mounts

These allow you to reduce the vibrations transmitted from the unit to the surface it is standing on. Accessory supplied loose.

ALPR Pre-painted aluminium coil

This option uses finned pack coils with copper tubes and pre-painted aluminium fins.

ANTC Coil treated with anti-corrosion paints

The treatment is applied exclusively to finned pack coils with copper tubes and aluminium fins and consists of aluminium passivation and coating with a polyurethane base; a double layer of paint, of which the first passivates the aluminium and acts as primer and the second is a polyurethane based surface coating. The product has high resistance to corrosion and all environmental conditions.

The product has high resistance to corrosion and to all environmental conditions.

Protective treatment of the exchanger is strongly recommended if at least one of the points below is verified:

- there are obvious signs of corrosion on the exposed metal surfaces in the installation area
- the installation is located close to the sea coast
- the prevailing winds come from the sea and travel in the direction of the unit
- the environment is industrial with a significant concentration of pollutants
- it is an urban environment with a high population density
- it is a rural environment with the presence of organic discharges and effluents

For chiller units, this accessory also includes the "Cu/Al coil" accessory.

With reference to the protection criteria to follow, especially for installations close to the coast, refer to the section titled "Installations that require the use of treated coils".

GABB Packaging in wooden crate

The unit is protected by a custom-made wooden cage, including a wooden sled designed for loading into containers and a fixing system. The accessory can be used for container shipping. Loading on containers must be carried out at the factory. The accessory is incompatible with "Skid for shipping in containers".

RAM Antifreeze oversized heater for condensate drip tray

The unit is fitted as standard with a heating cable glued to the bottom of the condensate tray to prevent formation of ice.

RAM accessory provide an oversized electrical heaters system.

Heaters are managed with a thermostat , activated depending on outside air temperature.

If the unit is designed to work as sizing point or as prolonged operating condition in this area then RAM accessory is mandatory. If the unit will be rarely having this working condition with for example cold winds then it's recommended base on local assessment.

RETE Coil protection net

TECHNICAL SPECIFICATIONS

GEYSER SKY Hi HP R0

			20	25	30
Cooling					
Refrigeration capacity	(1)	kW	16.73	22.5	27
Total absorbed power	(1)	kW	6.37	8.7	10.8
EER	(1)		2.63	2.57	2.5
Heating					
Heating capacity	(2)	kW	19.82	25.02	30.79
Total absorbed power	(2)	kW	5.89	7.94	10
COP	(2)		2.89	2.81	2.81
Compressors					
Compressors/Circuits		n°	1/1	1/1	1/1
Minimum capacity reduction step	(7)	%	17	17	17
Refrigerant charge HP	(3)	kg	1.6	2	2.4
Fans					
Quantity		n°	2	2	2
Total air flow rate HP		m³/h	19600	19600	19600
User-side heat exchanger					
Quantity		n°	1	1	1
Water flow rate CH	(1)	m³/h	2.9	3.9	4.7
Pressure drop CH	(1)	kPa	11	11	13
Water flow rate HP	(2)	m³/h	3.4	4.3	5.3
Pressure drop HP	(2)	kPa	14	15	18
Noise levels					
Sound power level cooling	(4)	dB(A)	82	82	85
Sound pressure level cooling	(6)	dB(A)	50	50	53
Dimensions and weights**					
Length		mm	1715	1715	1715
Depth		mm	700	700	700
Height		mm	1738	1738	1738
Operating weight		kg	410	414	415

CH: chiller unit; HP: heat pump unit; MCHX: unit with microchannel coils

(1) External air temperature of 35°C and user-side heat exchanger water inlet-outlet temperature of 12-7°C. Values compliant with standard EN 14511

(2) Outside air temperature 7°C DB, 6°C WB; condenser inlet/outlet water temperature 40/45°C. Values compliant with standard EN 14511

(3) Theoretical values referred to the basic unit. The amount of gas actually charged in the unit may differ.

(4) Unit operating at rated capacity, with no accessories of any kind - external air temperature 35°C and water input/output temperature from/to heat exchanger and user equal to 12/7°C. Values taken by measurements made in accordance with standard ISO 3744 and the Eurovent certification programme, where applicable. Binding values See NOISE LEVELS section.

(5) unit operating at nominal operating capacity, with no accessories of any kind, with external air temperature of 7°C (6°C WB) and user-side heat exchanger water inlet/outlet temperature of 40/45°C. Values obtained from measurements carried out in accordance with standard ISO 3744.

(6) Values obtained from the sound power level (conditions: note 4), related to a distance of 10 m from the unit in free field with directivity factor Q=2. Non-binding values See NOISE LEVELS section.

(7) Approximate value. The minimum capacity reached by the unit depends on the operating conditions. The value shown may not be suitable for calculating the minimum volume of water: to do this, consult the "Minimum water content in the system" section.

** Basic unit without included accessories

The certified standard performances and data can be verified in <https://www.eurovent-certification.com>

Some voluntary data are not certified (i.e. Noise Level for water source units; SCOP for units with Pdesign >70 KW; SCOP MT values).

GEYSER SKY Hi HP SLN R0

			20	25	30
Cooling					
Refrigeration capacity	(1)	kW	16.4	21.2	25.7
Total absorbed power	(1)	kW	6.4	8.7	10.9
EER	(1)		2.58	2.45	2.37
Heating					
Heating capacity	(2)	kW	19.82	25.02	30.79
Total absorbed power	(2)	kW	5.89	7.94	10
COP	(2)		2.89	2.81	2.81
Compressors					
Compressors/Circuits		n°	1/1	1/1	1/1
Minimum capacity reduction step	(7)	%	17	17	17
Refrigerant charge HP	(3)	kg	1.6	2	2.4
Fans					
Quantity		n°	2	2	2
Total air flow rate HP		m³/h	19600	19600	19600
User-side heat exchanger					
Quantity		n°	1	1	1
Water flow rate CH	(1)	m³/h	2.82	3.65	4.42
Pressure drop CH	(1)	kPa	11	11	13
Water flow rate HP	(2)	m³/h	3.41	4.3	5.3
Pressure drop HP	(2)	kPa	14	15	18
Noise levels					
Sound pressure lev. SLN vers.	(4)	dB(A)	80	80	83
Sound pressure lev. SLN vers.	(6)	dB(A)	48.4	48.4	51.4
Dimensions and weights**					
Length		mm	1715	1715	1715
Depth		mm	700	700	700
Height		mm	1738	1738	1738
Operating weight		kg	410	414	415

CH: chiller unit; HP: heat pump unit; MCHX: unit with microchannel coils

- (1) External air temperature of 35°C and user-side heat exchanger water inlet-outlet temperature of 12-7°C. Values compliant with standard EN 14511
(2) Outside air temperature 7°C DB, 6°C WB; condenser inlet/outlet water temperature 40/45°C. Values compliant with standard EN 14511
(3) Theoretical values referred to the basic unit. The amount of gas actually charged in the unit may differ.
(4) Unit operating at rated capacity, with no accessories of any kind - external air temperature 35°C and water input/output temperature from/to heat exchanger and user equal to 12/7°C. Values taken by measurements made in accordance with standard ISO 3744 and the Eurovent certification programme, where applicable. Binding values See NOISE LEVELS section.
(5) unit operating at nominal operating capacity, with no accessories of any kind, with external air temperature of 7°C (6°C WB) and user-side heat exchanger water inlet/outlet temperature of 40/45°C. Values obtained from measurements carried out in accordance with standard ISO 3744.
(6) Values obtained from the sound power level (conditions: note 4), related to a distance of 10 m from the unit in free field with directivity factor Q=2. Non-binding values See NOISE LEVELS section.
(7) Approximate value. The minimum capacity reached by the unit depends on the operating conditions. The value shown may not be suitable for calculating the minimum volume of water: to do this, consult the "Minimum water content in the system" section.

** Basic unit without included accessories

The certified standard performances and data can be verified in <https://www.eurovent-certification.com>

Some voluntary data are not certified (i.e. Noise Level for water source units; SCOP for units with Pdesign >70 KW; SCOP MT values).

ECODESIGN

INTRODUCTION

The Ecodesign/ErP Directive (2009/125/EC) lays down new standards for more efficient energy use.

The Directive contains various regulations; as regards chiller products and heat pumps, the regulations of interest are the following:

- Regulation 2013/813, for small heat pumps ($P_{\text{design}} \leq 400$ kW)
- Regulation 2016/2281, for chillers and heat pumps with $P_{\text{design}} > 400$ kW
- Regulation 2013/811, for heat pumps with $P_{\text{design}} \leq 70$ kW.

The last-mentioned regulation (2013/811) regards the labelling (Ecolabel certification) of small heat pumps.

The other two regulations (2013/813 and 2016/2281) set seasonal efficiency targets that the products must comply with to be sold and installed in the European Union (essential requirement for CE marking).

These efficiency limits are defined through ratios, which are respectively:

- η_{sh} (SCOP), with reference to regulation 2013/813
- η_{sc} (SEER) for comfort applications and SEPR for process applications, with reference to regulation 2016/2281.

The figure below schematically illustrates the correspondence between product and reference energy ratio.

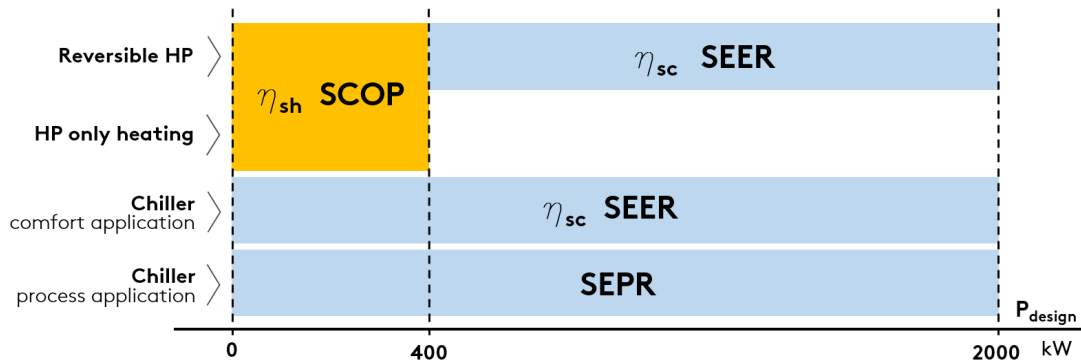

Some notes and clarifications:

For comfort applications, regulation 2016/2281 sets the η_{sc} (SEER) ratio in two different operating conditions:

- SEER calculated with machine inlet/outlet water temperature of 12/7°C (low temperature application),
- SEER calculated with machine inlet/outlet water temperature of 23/18°C (medium temperature application).

The minimum efficiency requirement is the same, but can be met at condition 12/7°C or at condition 23/18°C, depending on the application envisaged for the machine.

Regulation 2013/813 distinguishes two different types: at low temperature and at medium temperature.

The following refer to the application at low temperature: (low temperature application) all heat pumps whose maximum delivery temperature for heating purposes is lower than 52°C with source at temperature of -7°C and -8°C wet bulb (air-water unit) or inlet 10°C (water-water unit), at the reference design conditions for an average climate. For these, the efficiency ratio is "low temperature application" (outlet water temperature 35°C).

For all the other heat pumps, the efficiency ratio is related to "medium temperature application" (outlet water temperature 55°C).

The ratios must be calculated according to the reference European heating season in average climatic conditions.

The minimum efficiency requirements set by the regulations are indicated below.

REGULATION 2016/2281, comfort application

TYPE OF UNIT		MINIMUM REQUIREMENT	
SOURCE	P _{design}	η_{sc} [%]	SEER
air	< 400 kW	161	4,1
air	\geq 400 kW	179	4,55
water	< 400 kW	200	5,075
water	\geq 400 kW and < 1500 kW	252	6,375
water	\geq 1500 kW	272	6,875

REGULATION 2016/2281, process application

TYPE OF UNIT		MINIMUM REQUIREMENT
SOURCE	P _{design}	SEPR
air	< 400 kW	5
air	\geq 400 kW	5,5
water	< 400 kW	7
water	\geq 400 kW and < 1500 kW	8
water	\geq 1500 kW	8,5

REGULATION 2013/813

SOURCE	APPLICATION	MINIMUM REQUIREMENT	
		η_{sh} [%]	SCOP
air	low temperature application	125	3,2
water	low temperature application	125	3,325
air	medium temperature application	110	2,825
water	medium temperature application	110	2,95

The conformity of the product must be checked according to the type of application, whether comfort or process, and at the required outlet water temperature.

The two schematic tables below, respectively for comfort application and for process application, indicate the reference of the required conformity according to the type of product and the set point temperature (reference to regulations 2016/2281 and 2013/813).

Important note: for mixed comfort and process applications, the reference application for conformity is the comfort application.

COMFORT APPLICATION

PRODUCT	OUTLET WATER TEMPERATURE	COMPLIANCE INDEX	REGULATION
Chiller	< 18°C	SEER/η _{sc} low temperature application	2016/2281
	≥ 18°C	SEER/η _{sc} medium temperature application	2016/2281
Heat pumps (reversible and only heating) P_{design} ≤ 400kW		SCOP/η _{sh}	2013/813
Reversible heat pumps P_{design} > 400kW	< 18°C	SEER/η _{sc} low temperature application	2016/2281
	≥ 18°C	SEER/η _{sc} medium temperature application	2016/2281
Heat pumps only heating P_{design} > 400kW		-	-

- = exemption from Ecodesign

PROCESS APPLICATION

PRODUCT	OUTLET WATER TEMPERATURE	COMPLIANCE INDEX	REGULATION
Chiller	≥ +2°C , ≤ 12°C	SEPR	2016/2281
	> 12°C	-	-
	> -8°C , < +2°C	-	-

- = exemption from Ecodesign

Some specifications and notes follow.

Partly completed machinery

The term partly completed machinery refers to all units without a user-side or source-side heat exchanger, and therefore to all LC, LE, LC/HP and LE/HP versions. Since these are "non-complete" machines, conformity with Ecodesign depends on combination with the remote heat exchanger.

All the partly completed machinery is CE marked and accompanied by a declaration of conformity. Installation in European Union countries is therefore allowed; correct selection and installation of the remote heat exchanger must be ensured, in accordance with the above cases.

EC fans:

The only option that positively affects the performance of the unit, by increasing its seasonal energy efficiency ratio, is the VEC accessory.

GAMMA GEYSER SKY

Regulation 2013/813 applies specifically to the Geyser Sky range.

The tables below give information on the conformity of the units and the seasonal energy performance ratios with regard to the reference regulation.

GEYSER SKY Hi HP R0

			20	25	30
REGULATION 2013/813			-		
Pdesign	(1)	kW	15.9	19.7	24.6
COMFORT					
Standard Unit					
ηsh	(1)	%	166.2	175.8	179
SCOP LT	(1)		4.23	4.47	4.55
Unit with EC fans (VEC)					
ηsh	(1)	%	181	188.6	189.4
SCOP LT	(1)		4.6	4.791	4.809
REGULATION 2013/813			-		
Pdesign	(3)	kW	15.9	19.7	24.6
COMFORT					
Standard Unit					
ηsh	(3)	%	133.3	135.7	138.5
SCOP MT	(3)		3.407	3.467	3.538
Unit with EC fans (VEC)					
ηsh	(3)	%	139.6	141.6	142.4
SCOP MT	(3)		3.566	3.616	3.636
REGULATION 2013/811			-		
Standard Unit					
Ecolabel	(2)		A++	A+++	
Unit with EC fans (VEC)					
Ecolabel	(2)		A+++		

Y = unit in compliance with Ecodesign at the indicated condition. N = unit not in compliance with Ecodesign at the indicated condition: it can be installed only in non-EU countries.

- (1) User-side heat exchanger water inlet/outlet temperature 30/35°C, Average climate profile, with reference to regulation 2013/813 and norm EN 14825.
- (2) Energy efficiency class with reference to regulation 2013/811 (low temperature applications).
- (3) User-side heat exchanger water inlet/outlet temperature 47/55°C, Average climate profile, with reference to regulation 2013/813 and norm EN 14825.

GEYSER SKY Hi HP SLN R0

			20	25	30
REGULATION 2013/813			-		
Pdesign	(1)	kW	15.9	19.7	24.6
COMFORT					
Standard Unit					
ηsh	(1)	%	166.2	175.8	179
SCOP LT	(1)		4.23	4.47	4.55
Unit with EC fans (VEC)					
ηsh	(1)	%	181	188.6	189.4
SCOP LT	(1)		4.6	4.791	4.809
REGULATION 2013/813			-		
Pdesign	(3)	kW	15.9	19.7	24.6
COMFORT					
Standard Unit					
ηsh	(3)	%	133.3	135.7	138.5
SCOP MT	(3)		3.407	3.467	3.538
Unit with EC fans (VEC)					
ηsh	(3)	%	139.6	141.6	142.4
SCOP MT	(3)		3.566	3.616	3.636
REGULATION 2013/811			-		
Standard Unit					
Ecolabel	(2)		A++	A+++	
Unit with EC fans (VEC)					
Ecolabel	(2)		A+++		

Y = unit in compliance with Ecodesign at the indicated condition. N = unit not in compliance with Ecodesign at the indicated condition: it can be installed only in non-EU countries.

- (1) User-side heat exchanger water inlet/outlet temperature 30/35°C, Average climate profile, with reference to regulation 2013/813 and norm EN 14825.
- (2) Energy efficiency class with reference to regulation 2013/811 (low temperature applications).
- (3) User-side heat exchanger water inlet/outlet temperature 47/55°C, Average climate profile, with reference to regulation 2013/813 and norm EN 14825.

The certified standard performances and data can be verified in <https://www.eurovent-certification.com>

Some voluntary data are not certified (i.e. Noise Level for water source units; SCOP for units with Pdesign >70 KW; SCOP MT values).

ELECTRICAL SPECIFICATIONS

GEYSER SKY Hi HP R0

			20	25	30
General electrical specifications					
Max. absorbed current (FLA)	(1)	A	29.8	29.8	29.8
Nominal current (Inom)	(2)	A	9.8	13.3	16.4
cosφ standard unit	(2)		>0,95	>0,95	>0,95
Maximum inrush current (MIC)	(3)	A	9.8	9.8	9.8
Power supply		V/ph/Hz	400/3~+N/50	400/3~+N/50	400/3~+N/50
Power supply for auxiliary circuits		mm ²	230-24/1~/50	230-24/1~/50	230-24/1~/50
Suggested line section	(5)	mm ²	6	6	6
Suggested line protection	(6)		CH14gG 40A		
Electrical specifications for fans					
Rated power of standard fan	(1)	n° x kW	2x0,535	2x0,535	2x0,535
Rated current of standard fan	(1)	n° x A	2x2,4	2x2,4	2x2,4
Rated power of EC fan	(2)	n° x kW	2x0,825		
Rated current of EC fan	(2)	n° x A	2x1,4	2x1,4	2x1,4

GEYSER SKY Hi HP SLN R0

			20	25	30
General electrical specifications					
Max. absorbed current (FLA)	(1)	A	29.8	29.8	29.8
Nominal current (Inom)	(2)	A	9.8	13.3	16.4
cosφ standard unit	(2)		>0,95	>0,95	>0,95
Maximum inrush current (MIC)	(3)	A	9.8	9.8	9.8
Power supply		V/ph/Hz	400/3~+N/50	400/3~+N/50	400/3~+N/50
Power supply for auxiliary circuits		mm ²	230-24/1~/50	230-24/1~/50	230-24/1~/50
Suggested line section	(5)	mm ²	6	6	6
Suggested line protection	(6)		CH14gG 40A		
Electrical specifications for fans					
Rated power of standard fan	(1)	n° x kW	2x0,535	2x0,535	2x0,535
Rated current of standard fan	(1)	n° x A	2x2,4	2x2,4	2x2,4
Rated power of EC fan	(2)	n° x kW	2x0,825		
Rated current of EC fan	(2)	n° x A	2x1,4	2x1,4	2x1,4

- (1) Data regarding the unit without accessories working in maximum power absorption conditions
- (2) Datum related to the unit without accessories working in standard conditions (A35°C; W12-7°C)
- (3) Maximum effective RMS value of the current when the last compressor starts (FLA of the entire unit - FLA of the largest compressor + LRA of the largest compressor)
- (4) Maximum effective RMS value of the current when the last compressor starts (FLA of the entire unit - FLA of the largest compressor + 0.6 x LRA of the largest compressor)
- (5) These values are determined for cables with operating temperature of 40°C, EPR insulation and a line with a maximum length of 50m. The line section must be determined by a qualified technician based on the protection devices, the length of the line, the type of cable used and the type of installation.
- (6) The correct line protection part must be determined by a qualified technician based on the length of the line, the type of cable used and the type of installation.

HYDRAULIC MODULES

GEYSER SKY Hi HP R0

			20	25	30
Volume of the expansion vessel		I	18	18	18
Volume of the buffer tank HP		I	140	140	140
Standard pumps					
Pump model 1P			P1	P1	P2
Available head 1P	(1)	kPa	210	200	174

(1) External air temperature 35°C, user-side heat exchanger water inlet/outlet temperature 12/7°C. Values in accordance with EN 14511.

GEYSER SKY Hi HP SLN R0

			20	25	30
Volume of the expansion vessel		I	18	18	18
Volume of the buffer tank HP		I	140	140	140
Standard pumps					
Pump model 1P			P1	P1	P2
Available head 1P	(1)	kPa	210	200	174

(1) External air temperature 35°C, user-side heat exchanger water inlet/outlet temperature 12/7°C. Values in accordance with EN 14511.

The certified standard performances and data can be verified in <https://www.eurovent-certification.com>

Some voluntary data are not certified (i.e. Noise Level for water source units; SCOP for units with Pdesign >70 KW; SCOP MT values).

PUMP DATA

GEYSER SKY				
Model	Rated power	Rated current	Qmin	Qmax
	kW	A	m ³ /h	m ³ /h
P1	0,6	1,5	1,8	4,5
P2	0,9	2,1	3,6	9,6

USER-SIDE EXCHANGER FLOW RATE FIELDS

The units are sized and optimized for the following nominal conditions: external air 35°C, inlet-outlet of the user-side exchanger 12/7°C.

The units can work at design conditions different from nominal conditions, provided that:

- the design condition falls within the operating limits specified below
- the flow rate at design conditions (that is, of the specific application) must always come within the allowed flow rate ranges specified below. If the design conditions require a water flow rate that does not come within the allowed operating range, you must contact our sales department that will identify the most suitable solution for the specific application.

GEYSER SKY

	Qmin	Qmax
	m ³ /h	m ³ /h
20	1,7	5,1
25	2,2	6,5
30	2,6	7,9

OPERATING LIMITS

COOLING

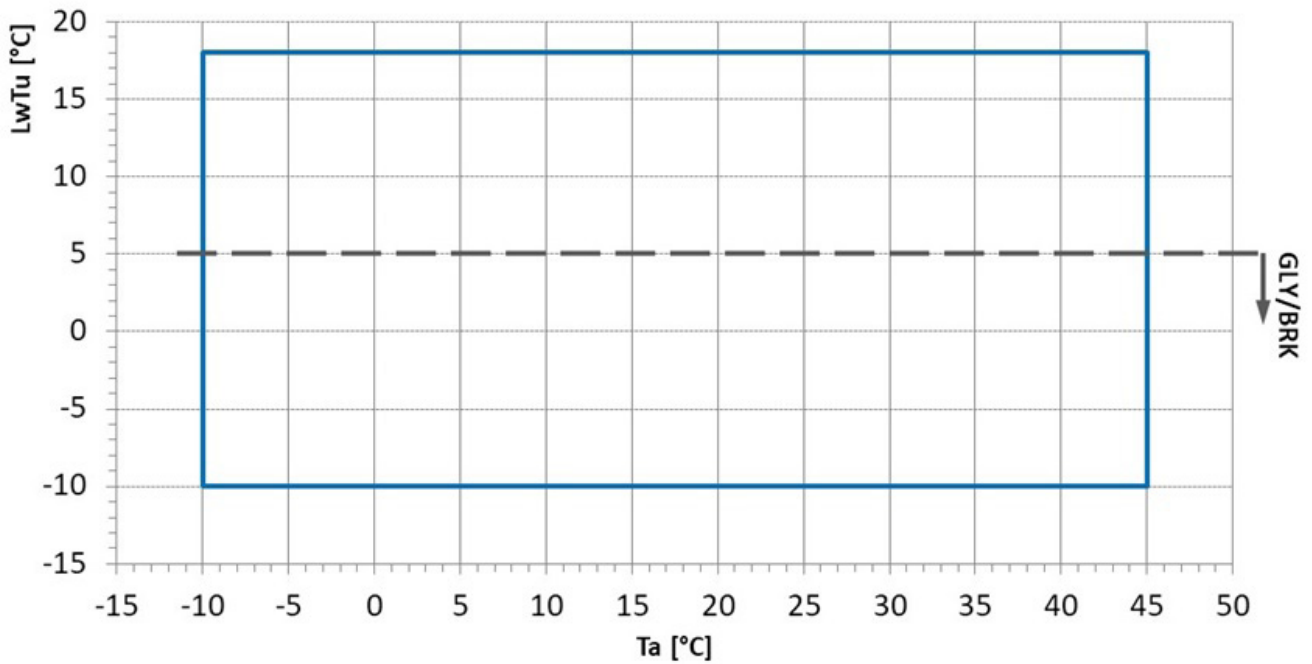

Ta: external air temperature

LWtu: water outlet temperature from the user-side heat exchanger

For LWtu below +5°C, it is compulsory to use suitable percentages of antifreeze additives (glycols) to prevent ice formation in the exchanger.

The inlet and outlet temperatures of the user-side exchanger must be given on ordering to allow correct setting of the alarm parameters and verification of the sizing of the expansion valve.

The cooling set point can then be changed by the customer in an interval that, compared to the set point given on ordering, ranges from -1K up to the maximum temperature allowed by the above-stated operating limits.

The unit will be optimized to work at the set point temperatures given on ordering. For different set points, the cooling capacity provided and the level of efficiency of the machine could decrease and move away from these conditions.

HEATING

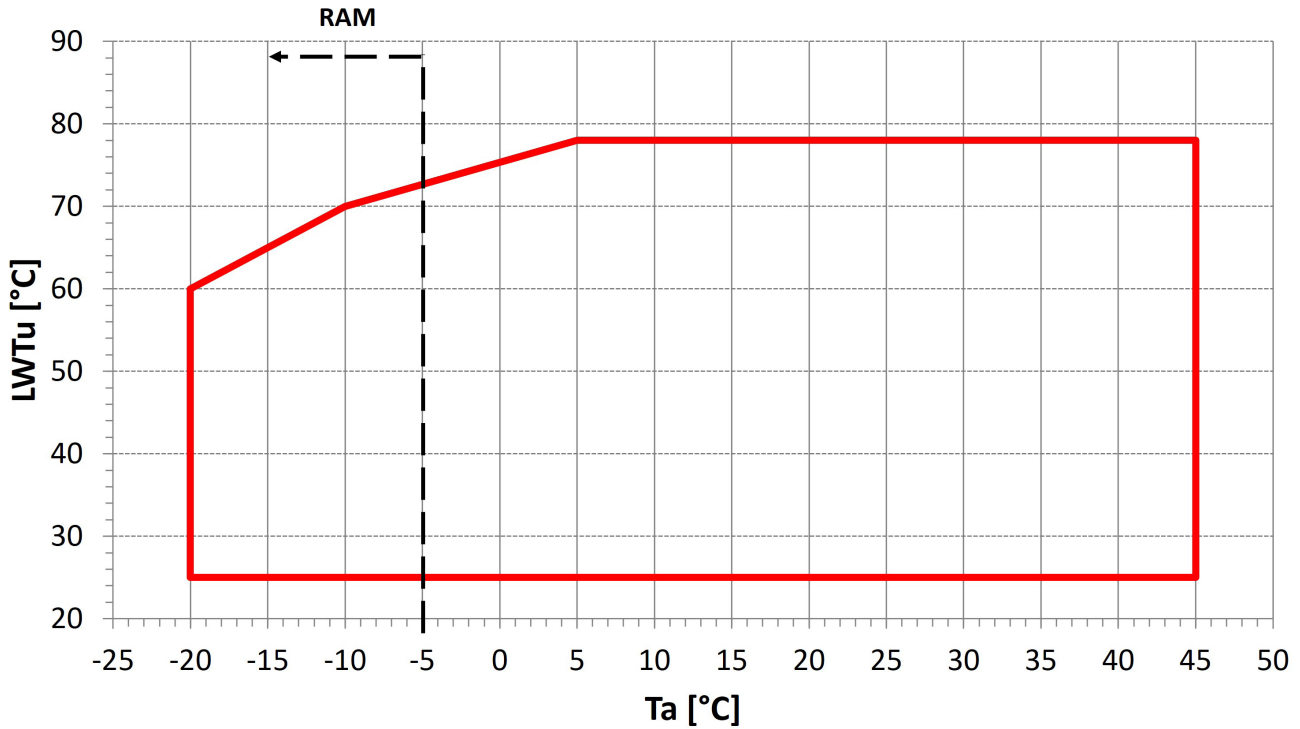

Ta: external air temperature

LWTu: water outlet temperature from the user-side heat exchanger

/RAM: in the indicated area, the unit can work only if fitted with the accessory /RAM. Recommended accessory for installations in regions with temperatures below -5°C or in the case of installations particularly exposed to cold winds.

For LWTu below +5°C, it is compulsory to use suitable percentages of antifreeze additives (glycols) to prevent ice formation in the exchanger.

The inlet and outlet temperatures of the user-side exchanger must be given on ordering to allow correct setting of the alarm parameters and verification of the sizing of the expansion valve.

The cooling set point can then be changed by the customer in an interval that, compared to the set point given on ordering, ranges from -1K up to the maximum temperature allowed by the above-stated operating limits.

The unit will be optimized to work at the set point temperatures given on ordering. For different set points, the cooling capacity provided and the level of efficiency of the machine could decrease and move away from these conditions.

NOISE LEVELS

GEYSER SKY Hi HP R0

Octave bands [dB]

Total

	63 Hz		125 Hz		250 Hz		500 Hz		1000 Hz		2000 Hz		4000 Hz		8000 Hz		[dB(A)]	
	Lw	Lp	Lw	Lp	Lw	Lp	Lw	Lp	Lw	Lp	Lw	Lp	Lw	Lp	Lw	Lp	Lw	Lp
20	75.1	43.5	85.1	53.5	84.8	53.2	78.5	46.9	74.1	42.5	74	42.4	66.4	34.8	61.5	29.9	82	50
25	75.1	43.5	85.1	53.5	84.8	53.2	78.5	46.9	74.1	42.5	74	42.4	66.4	34.8	61.5	29.9	82	50
30	80.3	48.7	90.3	58.7	90	58.4	79.4	47.8	75.3	43.7	76.6	45	71.2	39.6	68.1	36.5	85	53

Reference conditions: outside air temperature 35°C; input/output water temperature into/from user-side heat exchanger 12/7°C; unit operating at rated capacity, without any option.

Lw: sound power levels. Values obtained from measures taken according to standard ISO 3744. Lw_tot is the only binding value.

Lp: sound pressure levels. Binding values starting from noise power levels referred to a distance of 10 m from the unit; source installed on a reflective surface and in ideal free field conditions with directivity factor Q=2. Non-binding values

The acoustic data are related to standard conditions in referable and reproducible operating conditions. All data with the exception of Lw_tot are provided for illustrative purposes only and can not be used for forecasting purposes or for the verification of binding limits. With special reference to noise emissions, the Manufacturer takes liability for their conformity, limited to the declared Lw_tot value. Any and all other Manufacturer's liability for the impact of such emissions in relation to the location of the machine and other conditions related to machine installation is excluded. The environment and the installation conditions, as well as the operating modes, can alter the sound emissions. Any assessment concerning these conditions falls within the area of competence of the plant designer and/or the fitter.

GEYSER SKY Hi HP R0

Model		20	25	30
Sound Power Level declared according to Regulation (EU) No. 813/2013	dB(A)	71	71	71

GEYSER SKY Hi HP SLN R0

Octave bands [dB]

Total

	63 Hz		125 Hz		250 Hz		500 Hz		1000 Hz		2000 Hz		4000 Hz		8000 Hz		[dB(A)]	
	Lw	Lp	Lw	Lp	Lw	Lp	Lw	Lp	Lw	Lp	Lw	Lp	Lw	Lp	Lw	Lp	Lw	Lp
20	73.1	41.5	83.1	51.5	82.8	51.2	76.5	44.9	72.1	40.5	72	40.4	64.4	32.8	59.5	27.9	80	48.4
25	73.1	41.5	83.1	51.5	82.8	51.2	76.5	44.9	72.1	40.5	72	40.4	64.4	32.8	59.5	27.9	80	48.4
30	78.6	47	88.6	57	84.8	53.2	79.1	47.5	71.7	40.1	77	45.4	70.6	39	68.5	36.9	83	51.4

Reference conditions: outside air temperature 35°C; input/output water temperature into/from user-side heat exchanger 12/7°C; unit operating at rated capacity, without any option.

Lw: sound power levels. Values obtained from measures taken according to standard ISO 3744. Lw_tot is the only binding value.

Lp: sound pressure levels. Binding values starting from noise power levels referred to a distance of 10 m from the unit; source installed on a reflective surface and in ideal free field conditions with directivity factor Q=2. Non-binding values

The acoustic data are related to standard conditions in referable and reproducible operating conditions. All data with the exception of Lw_tot are provided for illustrative purposes only and can not be used for forecasting purposes or for the verification of binding limits. With special reference to noise emissions, the Manufacturer takes liability for their conformity, limited to the declared Lw_tot value. Any and all other Manufacturer's liability for the impact of such emissions in relation to the location of the machine and other conditions related to machine installation is excluded. The environment and the installation conditions, as well as the operating modes, can alter the sound emissions. Any assessment concerning these conditions falls within the area of competence of the plant designer and/or the fitter.

GEYSER SKY Hi HP SLN R0

Model		20	25	30
Sound Power Level declared according to Regulation (EU) No. 813/2013	dB(A)	71	71	71

The certified standard performances and data can be verified in <https://www.eurovent-certification.com>

Some voluntary data are not certified (i.e. Noise Level for water source units; SCOP for units with Pdesign >70 KW; SCOP MT values).

INSTALLATION ADVICE

The units described in this document are, by nature, strongly affected by the characteristics of the system, the working conditions and the installation site.

Remember that the unit must be installed by a qualified and skilled technician, and in compliance with the national legislation in force in the destination country.

The installation must be done in such a way that it will be possible to carry out all routine and non-routine maintenance operations.

Before starting any work, you must carefully read the "Installation, operation and maintenance manual" of the machine and do the necessary safety checks to prevent any malfunctioning or hazards.

We give some advice below that will allow you to increase the efficiency and reliability of the unit and therefore of the system into which it is inserted.

Water characteristics

To preserve the life of the exchangers, the water is required to comply with some quality parameters and it is therefore necessary to make sure its values fall within the ranges indicated in the following table:

Total hardness	2,0 ÷ 6,0 °f
Langelier index	- 0,4 ÷ 0,4
pH	7,5 ÷ 8,5
Electrical conductivity	10 ÷ 500 µS/cm
Organic elements	-
Hydrogen carbonate (HCO₃⁻)	70 ÷ 300 ppm
Sulphates (SO₄²⁻)	< 50 ppm
Hydrogen carbonate / Sulphates (HCO₃⁻/SO₄²⁻)	> 1
Chlorides (Cl⁻)	< 50 ppm
Nitrates (NO₃⁻)	< 50 ppm
Hydrogen sulphide (H₂S)	< 0,05 ppm
Ammonia (NH₃)	< 0,05 ppm
Sulphites (SO₃), free chlorine (Cl₂)	< 1 ppm
Carbon dioxide (CO₂)	< 5 ppm
Metal cations	< 0,2 ppm
Manganese ions (Mn⁺⁺)	< 0,2 ppm
Iron ions (Fe²⁺ , Fe³⁺)	< 0,2 ppm
Iron + Manganese	< 0,4 ppm
Phosphates (PO₄³⁻)	< 2 ppm
Oxygen	< 0,1 ppm

Installation of water filters on all the hydraulic circuits is obligatory.

The supply of the most suitable filters for the unit can be requested as accessory. In this case, the filters are supplied loose and must be installed by the customer following the instructions given in the installation, operation and maintenance manual.

Glycol mixtures

With temperatures below 5°C, it is mandatory to work with water and anti-freeze mixtures, and also change the safety devices (anti-freeze, etc.), which must be carried out by qualified authorised personnel or by the manufacturer.

Liquid outlet temperature or minimum ambient temperature	°C	0	-5	-10	-15	-20	-25	-30	-35	-40
Freezing point	°C	-5	-10	-15	-20	-25	-30	-35	-40	-45
Ethylene glycol	%	6	22	30	36	41	46	50	53	56
Propylene glycol	%	15	25	33	39	44	48	51	54	57

The quantity of antifreeze should be considered as % on weight

Minimum water content in the system

For correct operation of the unit, it is necessary to ensure a buffering on the system such as to comply with the minimum operating time considering the greater between the minimum OFF time and the minimum ON time. In short, these contribute to limiting the number of times the compressors are switched on per hour and to preventing undesired deviations from the set point of the delivered water temperature.

Larger amounts of water are in any case always preferable, because they allow a smaller number of starts and switch-offs of the compressors, less wear of them and an increase in the efficiency of the system as a consequence of a reduction in the number of transients.

It should also be pointed out that, for air-water units working in heat pump mode, the minimum amount of water must consider the need of the unit to carry out defrosting. Having an adequate buffering volume will allow prevention of too high drifts of the delivered water temperature at the end of the defrost cycle.

Please check "water Volume Design" Tool for a correct estimation of minimum water content of the system in "heat pump" working mode.

The following experimental formula allows to calculate the minimum water volume of the plant. The formula only refers to the operation of the unit in cooling mode.

$$V_{min} = \frac{P_{tot} \cdot 1000}{N} \cdot \frac{180}{\Delta T \rho C_p} + P_{tot} \cdot 0.25$$

where

V_{min} is the minimum water content of the system [l]

P_{tot} is the total cooling capacity of the machine [kW]

N: number of capacity reduction steps

ΔT : differential allowed on the water temperature. Unless otherwise specified, this value is considered to be 2.5K

ρ : density of the heat-carrying fluid. Unless otherwise specified, the density of water is considered

c_p : specific heat of the heat-carrying fluid. Unless otherwise specified, the specific heat of water is considered

Considering the use of water and grouping together some terms, the formula can be re-written as follows:

$$V_{min} = \frac{P_{tot}}{N} \cdot 17,2 + P_{tot} \cdot 0,25$$

N may take the following values:

- N=3 for units featuring one inverter-piloted compressor only;

Installation site

To determine the best installation site for the unit and its orientation, you should pay attention to the following points:

- compliance with the clearance spaces indicated in the official dimensional drawing of the unit must be guaranteed so as to ensure accessibility for routine and non-routine maintenance operations
- you should consider the origin of the hydraulic pipes and their diameters because these affect the radiuses of curvature and therefore the spaces needed for installing them
- you should consider the position of the cable inlet on the electrical control panel of the unit as regards the origin of the power supply
- if the installation includes several units side by side, you should consider the position and dimensions of the manifolds of the user-side exchangers and of any recovery exchangers
- if the installation includes several units side by side, you should consider that the minimum distance between units is 3 metres
- you should avoid all obstructions that can limit air circulation to the source-side exchanger or that can cause recirculation between air supply and intake
- you should consider the orientation of the unit to limit, as far as possible, exposure of the source-side exchanger to solar radiation
- if the installation area is particularly windy, the orientation and positioning of the unit must be such as to avoid air recirculation on the coils. If necessary, we advise making windbreak barriers in order to prevent malfunctioning.

Once the best position for the unit has been identified, you must check that the support slab has the following characteristics:

- its dimensions must be proportionate to those of the unit: if possible, longer and wider than the unit by at least 30 cm and 15/20cm higher than the surrounding surface
- it must be able to bear at least 4 times the operating weight of the unit
- it must allow level installation of the unit: although the unit is installed on a horizontal base, make slopes in the support surface to convey rain water or defrost water to drains, wells or in any case to places where it cannot generate an accident hazard due to ice formation. All heat pump version units are equipped with discharge manifolds for the condensed water; these can be manifolded to facilitate condensate discharge.

The units are designed and built to reduce to a minimum the level of vibration transmitted to the ground, but it is in any case advisable to use rubber or spring anti-vibration mounts, which are available as accessory and should be requested when ordering.

The anti-vibration mounts must be fixed on before positioning the unit on the ground.

In the event of installation on roofs or intermediate floors, the pipes must be isolated from the walls and ceilings.

It is advisable to avoid installation in cramped places, to prevent reverberations, reflections, resonances and acoustic interactions with elements outside the unit.

It is essential that any work done to soundproof the unit does not affect its correct installation or correct operation and, in particular, does not reduce the air flow rate to the source-side exchanger.

Definitions

For reasons of clarity, it has been deemed helpful to introduce a series of additional definitions;

- **User terminal side heat exchanger/Desuperheater**

This type of heat exchanger is used to transfer heat from or to the hydraulic circuit vector fluid and, hence, heat or cool the climate controlled environments. The desuperheater is a dedicated heat exchanger used to heat a specific hydraulic circuit. Such units normally consist of a brazed plate heat exchanger. Other types of heat exchanger may be used.

- **Source-side heat exchanger**

This type of heat exchanger is used to transfer the heat extracted from/yielded to the user terminal side hydraulic circuit vector fluid towards the outdoor air when cooling/heating the climate controlled environments. Usually, finned or micro-channel coils. Other types of heat exchanger may be used. For example, in the case of water dissipation type source units, either brazed plate or tube bundle heat exchangers may be used.

- **Refrigerant leaks**

Refrigerant gas escaping from the container/object used to store it; in the case of Chillers or Heat Pumps, the gas will escape from the refrigerating circuit or one of its components. As the refrigerants in question are flammable, under certain circumstances gas leaks may result in the formation of flammable or explosive atmospheres. Such instances include, but are not limited to:

- refrigerant gas leaks from the unit refrigerating circuit due to one of its components malfunctioning or being damaged;

- refrigerant gas leaks caused by the unit safety valve being activated;

- refrigerant gas leaks caused by the unit heat exchanger or finned battery being damaged;

- accidental release of refrigerant gas from the refrigerating circuit, or cylinders used to store the gas, during maintenance activities.

- **Installation Class (Ref EN378-1).**

The Standard defines for Installation Classes.

- **Access Category (Ref EN378-1).**

a = public; **b** = restricted or supervised; **c** = controlled or authorised.

- **Charge Limit (Ref EN378-1).**

The Standard defines maximum refrigerant charge limits, depending on the installation class, access category and type of refrigerant in use.

- **LFL (Ref EN378-1).**

The lowest percentage of a substance in air that can lead to flame propagation.

- **The safety class or category of a refrigerant fluid (EN 378-1).**

categorization of a substance as flammable or non-flammable, toxic or non-toxic.

- **ATEX Zone 2 (Ref. EN 60079-10-1 and IOM) and Safety Zone (Ref IOM)**

Zone 2 according to the Atex directive is an area in which the formation of an explosive atmosphere of air and flammable substances in the form of gas, vapor or mist is not likely during normal activities and, if it occurs, it is only of short duration.

- **Ignition Sources (Ref EN378-2).**

External sources that could lead to flame propagation in a combustible atmosphere.

- **Installation.**

Installation is defined as the unit positioned and installed correctly and operational as set out in the IOM manual. This definition does not include the activities involved in preparing the installation (construction of the hydraulic and electrical systems, realising the infrastructure, etc.) In addition to the reference standards, further information may be found in the Appendix to this document.

- **Electrical control panel**

Electrical control panel QE. The panel encloses all the electrical components, the terminal boards, the piloting inverters, the control boards, etc. The electrical panel has an integrated ventilation system. The panel control can be equipped with single or dual fan versions. For Electrical control panel Atex components are not mandatory.

- **Technical compartment**

Technical compartment VT. The technical compartment encloses all refrigerant circuit elements, excluding air coils for air/water units. An Atex gas sensor and Atex extraction fan are inside the technical compartment.

Applicable standards and regulations

The main regulatory framework is given by the complete EN378, while for a complete regulatory framework it is useful to refer to the final part of the Swegon guides on flammable refrigerants.

EN378: refrigerating systems and heat pumps

- EN378-1: Basic requirements, definitions, classification and selection criteria.
- EN378-2: Design, construction, testing, marking and documentation.
- EN378-3: Installation site and personal protection.
- EN378-4: Operation, maintenance, repair and recovery.

Installation types

Generally, an air conditioning unit is installed in rooms that are normally occupied by people, in general-purpose rooms or in dedicated technical room such as **machinery rooms**. Another possible option is unit installation **outdoors, in the open air**. Also, several access categories are defined for each installation. The type of installation and access category determine the maximum permitted refrigerant charge for the installation, depending on the type of refrigerant in use.

This guide specifically addresses:

- Hydronic climate control units; chillers and heat pumps for **Class III outdoor** installations (open space installations). In the case of Class III installation in open field where all the standard and manufacturer's standards relating to the installation of the unit are respected, there is no restriction on the amount of charge of the installed unit if the access category and type "c" (authorized access).
- Hydronic units for air conditioning, chillers and heat pumps for indoor installations, Class IV (ventilated enclosure). Where the installation is Class IV indoor version and complies with all statutory and manufacturer's requirements as regards unit installation, the maximum limit charge for units filled with refrigerant A3-R290 is 5 kg, with access category types "b" and "c". Please be aware that, according to Table C.1 in Annex C to standard EN 3781, installations must not be placed in spaces at higher levels that are not provided with emergency exits or in spaces below ground level as this may pose some additional restrictions in terms of minimum volume that may depend on inspections of the level of toxicity of the refrigerants in use.

For further information regarding installation classes, access categories and the charge limit, consult the Standard EN378-1.

Compliance with class III or class IV is also linked to the fact that the hydraulic system that carries the fluid that is heated or cooled by the unit to the various users complies with the requirements defined by EN 378-1 in section 5.5. 2 to avoid the possibility of a leak of refrigerant flowing into occupied rooms. See the section "Hydraulic Connections" for a description of the various solutions that are applicable to our types of unit.

Failure to comply with the provisions regarding the hydraulic system will result in the installation being downgraded to Class I or Class II, in which case the refrigerant charge limits are lower than in Class III and Class IV (Ref. EN 378-1, Annex C).

In general, **the person in charge of the installation** (generally the designer), must ensure compliance with the standard requirements by carrying out a risk assessment mainly according to the manufacturer's instructions and standards, such as EN378-1, EN378-3, or IEC 60335-2-40:2018 when applicable. All other considerations aside, the installation must also conform with the applicable local or national regulations.

The installation technician must install the units as defined in the project. Before starting to install the units, the installation technician must carry out his/her own assessment, within the limits of his/her technical qualifications and issue the Declaration of Conformity once the work is complete.

The installation supervisor is responsible for guaranteeing the conformity of the system.

We strongly recommend that a consultant/qualified third-party body be involved in the installation conformity assessment process, based on the type and quantity of refrigerant used.

In order to ensure complete safety of the application, it is fundamentally important to respect the type of installation the unit has been designed for.

Where more stringent than the provisions set out in the applicable regulations, the installation shall conform to the local/national regulations.

Class III hydronic unit installations in open air environments

In order for the outdoor installation of units containing flammable and non-toxic refrigerant to be considered class III, the following are some of the additional assessments that the responsible for the installation (customer, installer, consultant, ...), must do to ensure that any gas leak does not generate dangerous situations.

1. The units must be positioned so as **to prevent any refrigerant leaks** from reaching the enclosed spaces, creating temporarily flammable zones or harming persons or property. Leaks must be prevented from flowing into manholes and storm drains and directly onto personnel and must not be directed towards air vents designated to serve enclosed spaces. Leaks must also be kept away from fresh air intakes, doors or similar openings, as well as ignition sources as defined by the Standard EN378-1. here is an obligation to convey the discharge of the safety valves via piping compliant with national and/or European directives, the area of which the refrigerant escapes must comply with the same requirements described above valid in the event of a leak.

The installation, use and maintenance manual and the dedicated documentation offer a detailed explanation of how the drainage channel must be created and calculated and any identification requirements required, but it must be remembered that the responsibility falls in any case on the person in charge of the installation.

Standard EN13136:2019 should be referenced for the calculation and sizing of the safety valve exhaust.

The conveying must be done with a pipe whose diameter must be at least that of the valve outlet, and the weight of the pipe must not be borne by the valve.

When positioning the safety valve discharge line, it should be taken into account that the Atex-Zone 2 generated by the emissions from a safety valve differs from the Atex Zone 2 defined for the unit.

More comprehensive information on the extent of Atex zone 2 at the outlet of the safety valve drain ducting can be found in the relevant instruction manual for installation, operation and maintenance of the unit.

The assessment of the risk areas is the responsibility of the installation supervisor.

Exhausted material must not be conveyed close to ignition sources, as defined in standard EN378-2.

Where the existing local regulations are more stringent, these should be taken as reference.

Always use the appropriate type of fire extinguishers for the refrigerant in use in proximity to the unit.

2. If the refrigerant leak can stagnate, for example, underground or inside cavities, the installation must comply with the requirements for gas detection and ventilation of engine rooms and where applicable , also compliant with the requirements for ignition sources as defined by EN378-2. Reference to the section on machinery rooms in standard EN 378-3 should be made in this case.

3. Where the unit is installed in the open air, but under a shelter, ventilation must be guaranteed.

4. If the unit installed is inside a room, where at least one of the longest walls is open to outside air for at least 80% of the wall area (or equivalent if more of a wall must be outdoors) and covered by slats/grids with at least 75% free area, is considered as an outdoor installation.

5. When conducting the risk assessment, the installation supervisor must also take the following indications into account.

- In the event of leaks, the unit gives rise to an Atex "zone 2" classified environment around the machine.
- Based on the above, the designation of a safety "zone/area" around the machine is deemed to be appropriate.

In a "zone 2":

- installation of equipment unsuitable for use in such potentially explosive zones must be avoided (the minimum equipment requirements are: 3G IIB T4);
- naked flames, sparks and hot work must be avoided;
- sources of ignition that are due to processes must be avoided, since they are likely to give way to remote ignition (ionizing and non-ionizing radiation);
- direct and indirect effects of electrocution must be avoided;
- electrostatic charges must be avoided;
- interference must be avoided with elements that may be hazardous, including sewage systems, openings towards stone retaining walls, underground spaces, power lines, flammable material warehouses, railways, motorways, etc.

In the safety "zone/area", storage of refrigerant bags must be avoided in spaces such as sewage systems, manholes, water traps, openings towards stone retaining walls, underground spaces, etc.

Refer to national or local regulations on this issue, where applicable.

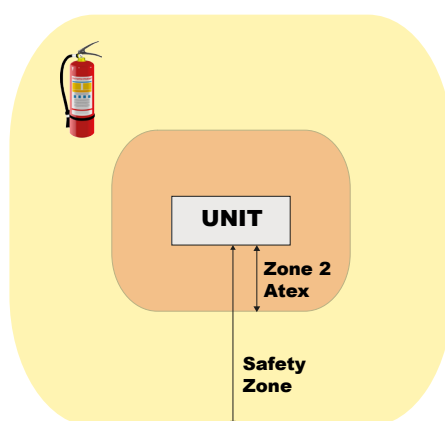

For further details, please refer to the "Instruction manual for operation and maintenance".

6. Confirm that noise barriers or other protection systems, if any, cannot create areas where leaks can stagnate.

7. Also take into account the possible leaks that can occur on parts of the circuit that are normally closed, for example from panels that can be removed or from doors that can be left open during maintenance activities.

Note:

To guarantee the correct functioning of the unit, it is mandatory to guarantee the clearances specified in the dimensional drawings. Always check the Atex Zone 2 and the respect/safety zone and any installation limitations in the Installation, Use and Maintenance manual.

Access restriction is part of correct installation to eliminate residual risks during normal operation.

Class IV installations (indoor units)

In order for Class IV indoor installation of units containing flammable and non toxic refrigerant to be compliant, please find below a list of additional evaluations that the installer must make with a view to preventing refrigerant leaks, if any, from generating hazardous situations

The safety valves are always fitted and their exhaust is routed outside the closing panels. Installation requirements and/ or national legislation require that the exhaust of safety valves is ducted outside. Where this is already the case, it must be ducted away from the unit.

The conveying must be done with a pipe whose diameter must be at least that of the valve outlet, and the weight of the pipe must not be borne by the valve.

The installation, use and maintenance manual and the dedicated documentation offer a detailed explanation of how the drainage channel must be created and calculated and any identification requirements required, but it must be remembered that the responsibility falls in any case on the person in charge of the installation.

The safety valves outlet must be conveyed using pipes in compliance with the national and/or European directives: the exhaust point must not be close to trap-doors, manhole covers and any other opening where refrigerant may be contained; the drained refrigerant must not be conveyed close to fresh air inlets, doors or similar openings; the drained refrigerant must not be ducted close to ignition sources, as defined in standard EN 378-2.

Standard EN13136:2019 should be referenced for the calculation and sizing of the safety valve exhaust.

Exhausted material must not be conveyed close to ignition sources, as defined in standard EN378-2.

The assessment of the risk areas is the responsibility of the installation supervisor.

Where the existing local regulations are more stringent, these should be taken as reference.

Always use the appropriate type of fire extinguishers for the refrigerant in use in proximity to the unit.

In accordance with the definition of "ventilated enclosure", a fan is provided that prevents the air flow from reaching the room where the unit is installed and causes a forced fresh air inlet. Exhausted air flows outside through ducts that are isolated from the space where they are installed. The technical compartment in which the unit is installed must be at least 10 times the volume of the unit. Should a leak occur, the fan is started and fresh air must be able to flow into the room to offset the exhaust air. The fan must be compliant for use in explosion atmosphere (ATEX).

It is mandatory, and responsibility of the installer, to install a duct for a correct routing of the air ejected from the technical compartment into the open air. The air exhaust duct must be compliant with the requirements laid down in standard EN 378-2 6.2.15. The air duct must not present sources of ignition. It is essential to ensure that the air is not expelled in proximity to storm drains, manholes, or any other opening that may contain refrigerant; in proximity to fresh air intakes, doors or similar openings, or in proximity to ignition sources, as defined by the Standard EN378-2.

Comprehensive and detailed information, including technical data concerning the fan flow rate and head required for correct implementation of the air exhaust ducting, as well as the flow rate of fresh air to be provided in the room where the unit is installed, are available in the specific instruction manual for operation and maintenance of the relevant units.

Hydraulic Connections

The chillers and heat pumps are normally used to heat and/or cool a closed water circuit connected to system terminals such as fan coils, etc., which are usually located in occupied spaces. The plumbing then connects the building utilities with the refrigeration machine, so in Class III and Class IV installations, for compliance to occur, the installer must take extra precautions to prevent a refrigerant leak into the hydraulic circuit through the heat exchanger then flows inside occupied rooms and or generates a flammable mixture, as required by EN 378-1 and EN378-3.

- The hydraulic system must be protected against accidental damage.
- An automatic air/refrigerant separator and a safety valve must be provided: these components must be installed as the first element at the outlet of the plate heat exchanger. The air/refrigerant separator and the safety valve must be placed at a higher level than the outlet of the heat exchanger where refrigerant may build up.
- Hydraulic components, accumulator tanks and any other open type components or elements that could release refrigerant as a consequence of a leak from the heat exchanger must be installed outdoors. The same safety precautions must be implemented as for any other potential source of leaks from the unit. If it is not possible to install such elements outdoors, they must be replaced with equivalent, watertight components.
- If there is a hydraulic decoupling device installed between the primary and secondary circuits, assess whether it is sufficient to implement the above precautions to the primary circuit only.

Outdoor installation always requires the fitting of safety valves. The air/refrigerant separators must be installed in an outdoor space. The option exists to evaluate installation of these components indoors, provided that in such case the air exhausted from these components must be ducted outside. The installer shall carry out a flammability assessment and a classification of the danger zone in the exhaust area, as required by standard EN 378-3. In the event that the installation solutions defined in the previous points are not possible but these devices are confined within a machine room, it is the duty of the installation manager to carry out a flammability assessment and classification of the danger area for the room technical as required by the EN378-3 standard".

The precautions implemented on the desuperheater hydraulic circuit must be the same as those adopted for the main heat exchanger.

All the units in heat pump version are equipped, at the base of each condensing/evaporating coil, with a condensate drip tray provided with an electric heater

If refrigerant leaks from the condensing coils, it may flow out through condensate pipework. Do not duct the refrigerant in pits, downpipes or any other opening where the refrigerant may build up and/or flow to sources of ignition, as defined in EN 378-2.

Guidelines for the risk assessment

The purpose of this section is to provide all elements specific to the Swegon Operations S.r.L. production units. with A2, A2L and A3 refrigerants to allow the installation manager to carry out the risk assessment associated with the installation and, consequently, to determine the prevention, protection and management measures to be adopted to pursue the following safety objectives:

- minimise the causes of fires or explosions;
- guarantee the stability of the supporting structures for a predetermined period of time;
- limit the instance and spread of fires inside the building;
- limit the spread of fires to adjacent buildings;
- limit the effects of explosions;
- ensure that occupants are able to leave the building unassisted or receive assistance in other ways;
- ensure that emergency services are able to intervene in conditions of safety.

The installation supervisor is responsible for compiling the installation risk assessment.

The information is in accordance with the European standard EN378 with particular reference to the effects on the environment and on the safety of people and things in the context linked to the installation of Swegon Operations S.r.L. production units. containing refrigerants classified A2L, A2 and A3.

The Technical Handbook includes information regarding the manufacturing specifications, technical and performance data, available accessories and all the other elements necessary for a full understanding of the units.

The Installation, Operating and Maintenance manual contains the information necessary to install, operate and service the units.

The technical data label, the additional labels, the wiring diagram, the refrigeration diagram, the hydraulic diagram, the dimensional diagram, the instructions concerning handling and the accompanying documentation show technical data, dimensions, clearances, data and electrical characteristics and hydraulics, utility connections, handling information and much more.

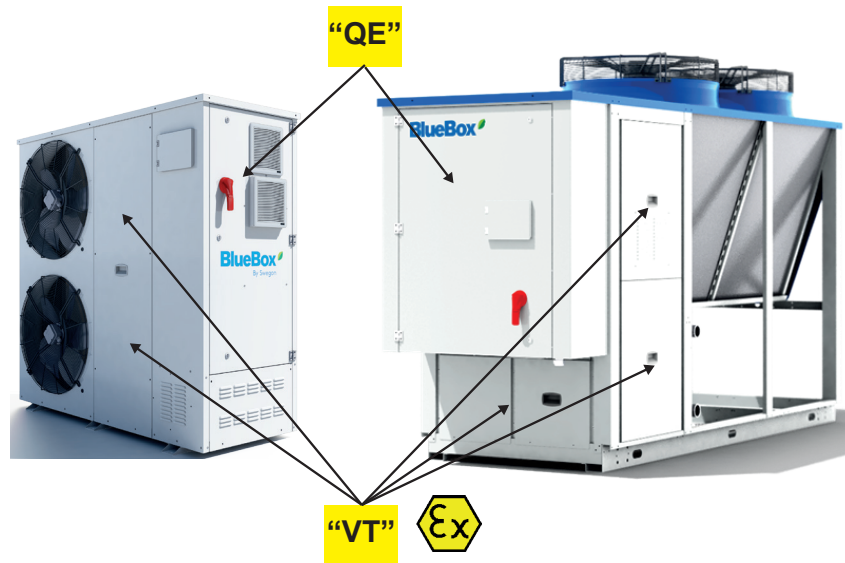

Thus, when defining the project and conducting the risk assessment, it is necessary to take various situations into account, including:

- how to properly convey any gas exhausted by the safety valves and how any leakage from the coils or any exhaust from the technical compartment (VT) may be made to flow to the safe area, as described above;
- a check that any leak in the "VT" is sensed by the refrigerant sensor a the time when the concentration exceeds 10% the LFL. The three-phase power supply is cut out and the unit consequently switches off. The extraction fan in the "VT" is started so that the air-refrigerant mix is expelled to the outside. The fans in the electric panel (QE) are switched on, if they are not already. The rest of the unit is off and the safety device chain only is active. The unit reports the leak condition by means of a light indicator and through a potential-free contact. After the leak is cleared safely, the sensor requires resetting, which is done by cutting out power to the sensor. When the sensor is energised again, a "warm-up" procedure gets started. A reading test is recommended after a leak has been identified;
- where a leak external to the "VT", originating from the unit batteries, is not detected by the refrigerant sensor but is prevented from entering the "QE" due to it being isolated. If the leak were to reach the axial fans, the speed of the air and effect of dilution would cause it to be dispersed. If the leaking gas manages to access the "VT", the previous case applies;
- if the sensor experiences a malfunction or power to it is cut out, but the unit is energised, the system basically starts the same actions listed for any leakage detected inside the "VT". Dedicated warning lights/messages are activated in this case, which are different from those relating to a leak;
- a blackout of the three-phase line switches the entire unit off, safety device chain included;
- a short blackout does not normally require an inspection by a qualified technician before the power line is restored;
- if the power failure lasts for a long time, we strongly recommend that a skilled technician be asked to test the unit for leaks on site: this evaluation must be part of the risk analysis;
- in any case, as soon as power is restored, the sensor runs the warm-up procedure, at the end of which an OK signal is output, where no leaks are identified, to restore power to the rest of the unit.

Despite the requirements adopted in units containing A3 flammable refrigerants, and although some components may be ATEX compliant, Swegon Operations units containing A3 **refrigerants are not suitable** to be installed in explosive environments as required by the ATEX directive.

Installation risk assessment

Transport, positioning and storage are not included in the scope of the installation risk assessment. The section "Reception, handling and storage of units containing flammable refrigerants" of this document provides information of performing these phases correctly and as safely as possible.

The residual risks described in the Installation, Operating and Maintenance manual must also be taken into account when conducting the risk assessment.

The following table contains a series of indications designed to assist the installation supervisor in conducting the risk assessment, and in minimising the risks themselves.

How to minimise fire risks in the installation.

Installing the unit	<p>The unit must be installed in a workmanlike manner, by a certified and titled company, respecting the manufacturer's specific instructions given in the IUM manual and adopting all the necessary fire prevention, protection and management measures.</p> <p>The unit must be installed outdoors in such a way as to prevent any refrigerant leaks from reaching the enclosed spaces, creating temporarily flammable zones or harming persons or property. Suitable fire extinguishing systems, corresponding to the type of refrigerant in use, must be installed in the vicinity of the unit.</p>
Ignition sources	<p>There must not be any ignition sources present inside the Atex Zone 2 of the unit, if such a zone is defined for the unit/installation being assessed. If no Atex Zone 2 is defined, the installation supervisor is responsible for assessing the presence/vicinity or otherwise of ignition sources, depending on the type of unit, the refrigerant in use, the installation, etc.</p>
Refrigerant stagnation areas	<p>There must not be any refrigerant stagnation areas, where refrigerant could be trapped in the event of a leak, present inside the unit safety zone.</p>

Refrigerant leaks

From the unit refrigerating circuit.

The unit refrigerating circuit, which is housed inside the technical compartment, is fitted with a refrigerant detector that is tripped if the concentration exceeds 10% of the LFL. The technical compartment is purged by expelling the refrigerant, which mainly builds up under the finned coils. The refrigerant is expelled by means of Atex fans. **The Atex Zone 2 and Safety zone must be respected.**

From the source side heat exchanger.

The leak is external to the unit and, if it does not enter the technical compartment, the unit continues to operate. In this case, the electrical components in the technical compartment are not affected by the leak. The leak cannot reach the electrical panel if the installations specifications have been respected. It should be taken into account the fact that, if the installation is located nearby marine environments or in the presence of aggressive atmospheres, and the coils are not treated accordingly, there is a greater chance of leaks. **If defined, the Atex Zone 2 and Safety zone must be respected.**

From the user terminal side heat exchanger.

The refrigerant leak flows from the refrigerating circuit towards the hydraulic system via the heat exchanger. The leak is not detected and the unit continues to operate. It **is obligatory** to respect the provisions relating to the hydraulic system. If the installation includes vents or deaerators, the risk assessment may also involve defining specific Atex 2 zones.

From the safety valve vent.

Correct discharge of the refrigerant vented by the safety valves plays a **fundamental** role in minimising fire risks. Such leaks must be routed as set out in the IOM manual, taking into account the fact that the outlet of the discharge line gives rise to an additional **Atex 2 Zone, which must also be respected**

External to the unit but not deriving from it

The unit is not suitable for use in flammable atmospheres. The leak must be detected as set out in the applicable standards and the unit made safe; for example, the unit must be completely isolated from its electrical power supply until the fault has been corrected and the flammable atmosphere eliminated.

#B#Main procedures that should be adopted:

- The use of either forced or natural ventilation helps to dilute the refrigerant and dissipate it in the surrounding air more rapidly.
- The electrical power supply to all devices not designed to be operated in flammable atmospheres should be interrupted if they are affected by the leak.
- All potential ignition sources that may be affected by the leak must be removed, if present.
- Avoid creating areas where build ups of refrigerant may accumulate, resulting in localised zones where flammable atmospheres may be present.
- Refrigerant must be prevented from reaching closed or occupied spaces, fresh air intakes, windows and other openings.
- The refrigerant Propane-R290 is heavier than air, which means that it tends to build up close to ground level.
- Additional safety procedures may be implemented, depending on the specifics of the individual installation site.

Unit refrigerant detector fault When a detector fault is identified, the unit enters safe mode, disconnecting all the electrical components not designed to be operated in flammable atmospheres from their power supply. The unit stops working. Only the technical compartment extractor fans, the electrical panel cooling fans and the leak sensor remain energised. This is **not** a leak condition, but it is necessary to check the refrigerant detector and restore correct operation as soon as possible.

Generic unit fault A generic fault does not give rise to a refrigerant leak. A fault that does give rise to a leak falls with the description provided above.

Fault on the extractor fan The unit handles a potential refrigerant leak in safe mode, as described above, disconnecting all the electrical components not designed to be operated in flammable atmospheres from their power supply. Refrigerant leaks from the technical compartment are slower, but spread to all parts of the compartment, rather than being concentrated mainly under the finned coil. **If defined, the Atex Zone 2 and Safety zone must be respected.**

It is important to recall that, when installing units containing A3 classified refrigerants, it may be necessary to obtain permission from the relevant Authority.

Suggestions for conducting and drawing up the risk assessment

This section contains an example that highlights the possible requirements to be complied with and the minimum information that must be filled in by the installation manager when drafting the risk assessment for a typical installation. The abbreviations describe the contents to be inserted in the various columns.

- **App.** = applicability of the provision (complete the empty fields according to the type of installation).
- **A** = the provision is applicable. It is possible to indicate a limit, a threshold, a distance, etc. that must be respected. If no indications are present, the provision is applicable but it is not necessary to respect any limits. For example, if an Atex zone 2 is defined, there is a minimum distance to respect and this is the limit to indicate, while in the case of the presence of fire extinguishers, it is sufficient that the fire extinguishers are present, therefore there is no limit to indicate. **Attention:** where they are more stringent, always refer to the local regulations for clarification regarding the applicability of the provisions. Since they are applicable for this type of installation, certain provisions are already indicated as applicable in the following example.
- **Conf.** = prescription compliance. Indicate whether the prescription is complied with or not. All non-conformities must be described in detail in the list at the bottom of the table, in correspondence with the number of the note specified when assigning responsibility for the non-conformity.
- **Doc.** = prescription reference document (fill in the empty fields in accordance with the assessment specifying any additional documents).
- **Note** = indicate a note reference, to be included in the footer list with explanation of the item, if necessary. It is also possible to insert a brief description in the case of applicability and conformity.

The risk assessment must include the following fields:

- Name of the installation site.
- Town/City.
- Address.
- Proprietor.
- Intended use.
- Person responsible for the risk assessment.
- Date.

It is also useful to include a list of the principal reference documents that should be adopted when drawing up the risk assessment (complete with the respective abbreviations).

The following documents constitute an integral part of the machine documentation. The documents are indicated by the abbreviations used to refer to them in the risk assessment.

- **IOM:** Installation, Operating and Maintenance manual This is the document where it is possible to find information relating to product safety and the correct way of operating, information on installation, Atex zone 2, safety zone and on the specific prescriptions relating to flammable refrigerant, start-up and maintenance of the units, as well as information on the competent personnel who may operate. This document is essential for personnel assigned install and operate the unit.
- **DimDiag:** The dimensions diagram illustrates the physical dimensions of the unit and the respective operating spaces.
- **ELDiag:** The electrical circuit diagram includes all the information regarding the unit electrical connections and the external connections to the unit.
- **Declaration of Conformity:** this document indicates the various EEC Directives and Regulations the unit conforms to.
- **PDoc:** an assessment conducted by the installation technician or other personnel responsible for the installation site.
- **TH:** Technical handbook or catalogue This document covers the technical and electrical data, the hydronic units and pumps; it includes the unit operating limits and various other information. This document is essential when designing a unit installation, especially in the case of projects that include units containing flammable refrigerants.

It is important to recall that, when installing units containing A3 classified refrigerants, it may be necessary to obtain permission from the relevant Authority.

So the risk assessment could be drafted as follows and contain, for example, the following information:

Unit model:	App.	Doc.	Conf.		Notes
Serial No.: SB.....			Yes	No	
Type of Refrigerant:					
Quantity of refrigerant (kg):					
Circuit 1 =					
Circuit 2 =					
Circuit 3 =					
Circuit 4 =					
Classification (A2L, A3, Other):					
Installation specifications.					
Operative clearance spaces - single unit.	A	SchDI			
Operative clearance spaces - adjacent units.	A	IOM			
ATEX 2 Zone Refrigerant leak - refrigerating circuit.	A	IOM			
ATEX 2 Zone Safety valves discharge: horizontal.	A	IOM			
ATEX 2 Zone Safety valves discharge: vertical.	A	IOM			
Safety zone.	A	IOM			
Type of installation (indicate class and access category).	A	IOM			
Charge limit (indicate charge limit value).	A	EN378-1			
Access to the area around the unit is restricted to qualified personnel only.	A	IOM			
Fire extinguishers suitable for use on Propane in the vicinity of the unit.	A	IOM			
		EN378-3			
Ventilation guaranteed.	A	IOM			
		EN378-3			
It is forbidden to smoke or carry out any activities that involve introducing ignition sources into the ATEX 2 zone.	A	IOM			
		EN378-3			
Presence of one or more emergency circuit breakers for interrupting the power supply to the unit.		EN378-3			
Presence of refrigerant detectors in the installation (indicate trip setting level and area covered).					
Refrigerant leaks must not occur in the vicinity of ignition sources, fresh air inlets, closed and/or occupied spaces, doors or similar openings, manholes, storm drains or any other opening that could contain the refrigerant.		IOM			
		EN378-3			
The installation site conforms to the fire prevention directives (indicate reference document).					
The escape routes must conform to the requirements of the fire prevention directive (indicate reference document).					
Other, depending on the characteristics of the installation.					
Unit safety valves.					
Safety valve discharge line.	A	Pdoc			

Unit model:	App.	Doc.	Conf.		Notes
Serial No.: SB.....			Yes	No	
i. Manufactured according to IUM, dimensional scheme and national directives.	A	IOM			
ii. Inner diameter not less than the diameter of the safety valve outlet.	A	SchDI			
iii. The weight of the pipe must not weigh on the safety valve.	A	IOM			
iv. Sealed from the surrounding environment.	A	IOM			
	A	EN378			
v. There must be no sources of ignition inside the exhaust pipe.	A	IOM			
	A	EN378			
vi. Calculation and sizing of the drain.	A	EN13136:			
	A	2013			
vii. Escaping refrigerant must not be in the vicinity of sources of ignition, fresh air intakes, confined and/or occupied spaces, doors or similar openings of drains, manhole covers and any other openings which may contain refrigerant.	A	IOM			
		EN378-3			
viii. The drain must not cause damage to people or things.	A	IOM			
		EN378-3			
Unit equipment.					
Installing accessories.					
• Accessories suitable for use in flammable atmospheres.		Pdoc			
• Accessories not suitable for use in flammable atmospheres.		Pdoc			
• Other, according to unit configuration.					
Unit equipped with refrigerant leak sensor.	A	IOM			
• Read/run check at start up.	A	IOM			
• Periodic reading/operation check.	A	IOM			"e.g.(2)"
Unit equipped with ATEX cable glands.	A	IOM			
• Start-up tightening check.	A	IOM			
• Periodic tightening check.	A	IOM			

Unit model:	App.	Doc.	Conf.		Notes
Serial No.: SB.....			Yes	No	
Hydraulic circuits 1					
Hydraulic circuit in conformity with EN378-32.	A	IOM EN378-3			
• It is compulsory to use systems in the hydraulic system capable of eliminating the presence of refrigerant gas in the event of a leak (vents, safety valves, degassers, other). These systems must be outside or safely conveyed outside according to requirements similar to points iv, v, vii and viii of the item "safety valve discharge".	A	IOM EN378-3			
• The conveying pipe, if present, must be correctly sized and made according to the indications of the reference standard.	A	Pdoc			
• Open-type components connected to the plumbing system must be installed outdoors or replaced by sealed equivalents.	A	IOM EN378-3			
• Comply with the Atex zone 2 of the vents or safety valves of the hydraulic system (indicate the Atex Zone 2 limit).	A	Pdoc			
• Respect zone 2 Atex open components of the hydraulic system installed outdoors (indicate Zone 2 Atex limit).	A	Pdoc			
• Comply with Atex Zone 2 due to loss of refrigerant from the hydraulic system (indicate Atex Zone 2 limit).	A	Pdoc			
• Other, according to the characteristics of the hydraulic system.	A	Pdoc			
Electrical connections.					
The electrical connections must be realised in a professional manner by operators who are qualified to design and install electrical systems, in accordance with applicable international and national standards.	A	IOM			
The system must be connected to earth.	A	IOM SchEL			
Power supply voltage and frequency corresponding to the electrical data specified for the unit (indicate nominal values).	A	IOM			
	A	SchEL			
The weight of the cables must not be borne by the electrical connection system.	A	IOM			
The cross-section of the cable and the line protection devices must correspond to those indicated in the wiring diagram.	A	IOM			
	A	SchEL			
The passage of any cable from the outside to the inside of the electrical panel must only take place using cable glands suitable for the diameter of the cable; any free cable glands available in the electrical panel are suitable. Do not insert more than one cable per gland; do not use sheaths inside the cable glands.	A	IOM			
The electrical panel must not be drilled, modified or tampered with in any way; do not leave any apertures.	A	IOM			
Additional provisions regarding the installation site					
...					
Other					
...					

Installations that require the use of treated coils

If the unit has to be installed in an environment with a particularly aggressive atmosphere, coils with special treatments are available as options.

- coils with anti-corrosion treatment;

A description of the individual accessories is available in the "Description of accessories" section.

The type of coil treatment should be chosen with regard to the environment in which the unit is to be installed, through observation of other structures and machinery with exposed metal surfaces present in the destination environment.

The cross observation criterion is the most valid method of selection currently available without having to carry out preliminary tests or measurements with instruments. The identified reference environments are:

- coastal/marine
- industrial
- urban with a high housing density
- rural

Please note that in cases where different conditions co-exist, even for short periods, the choice must be suitable for preserving the exchanger in the harsher environmental conditions and not in conditions between the worst and best situation.

Particular attention must be given in cases where an environment that is not particularly aggressive becomes aggressive as a consequence of a concomitant cause, for example, the presence of a flue outlet or an extraction fan.

We strongly suggest choosing one of the treatment options if at least one of the points listed below is verified:

- there are obvious signs of corrosion of the exposed metal surfaces in the installation area
- the prevailing winds come from the sea towards the unit
- the environment is industrial with a significant concentration of pollutants
- the environment is urban with a high population density
- the environment is rural with the presence of organic discharges and effluents

In particular, for installations near the coast, the following instructions apply:

- **for units to be installed between 1 and 20 km from the coast, the use of the option "Coil treated with anti-corrosion paints" is strongly recommended;**
- **for units to be installed within one kilometre from the coast, the use of the option "Coil treated with anti-corrosion paints" is strongly recommended.**

To protect the exchangers from corrosion and ensure optimal operation of the unit, we advise following the recommendations given in the user, installation and maintenance manual for cleaning the coils.

DIMENSIONAL DIAGRAMS

DDIM001396

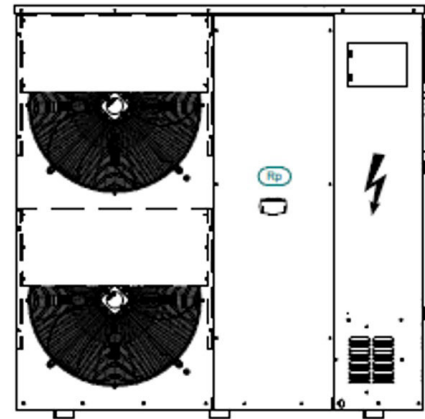
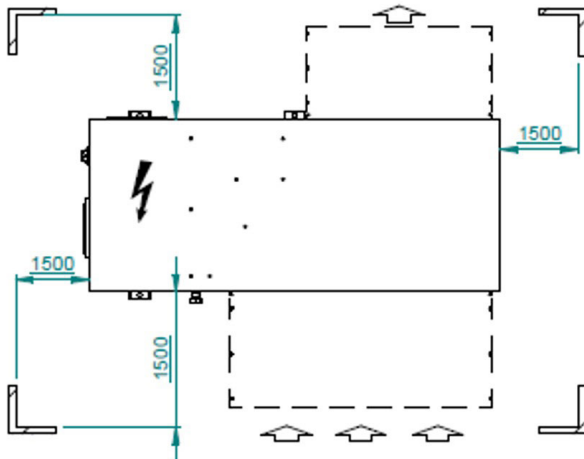
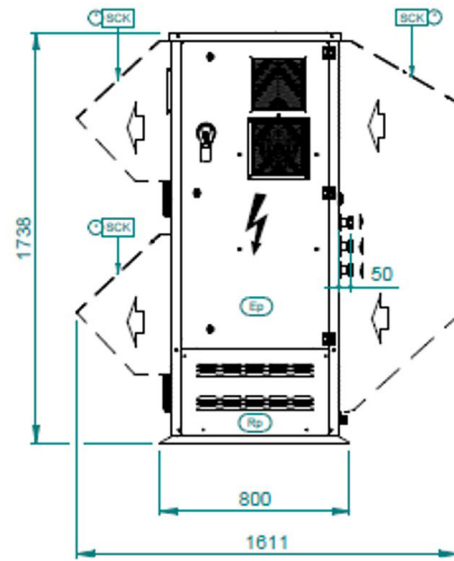
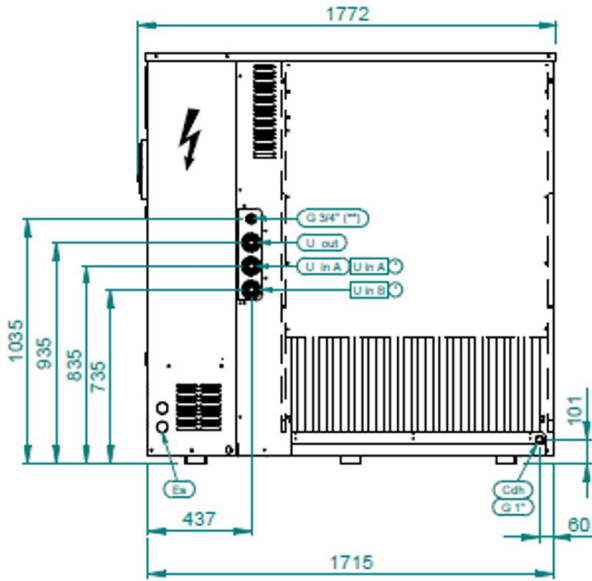

* OPTIONAL

** SAFETY VALVE DISCHARGE

SCK Snow covers kit

CONNECTIONS DIMENSIONS				
HYDR.CONFIG	SIZE	U in A	U in B	U out
GEYSER SKY HP	20-25	G 1"1/4	/	G 1"1/4
GEYSER SKY HP 1P	20-25	G 1"1/4	/	G 1"1/4
GEYSER SKY HP 1P+V3I	20-25	G 1"1/4	G 1"1/4	G 1"1/4

Note: These drawings are not contractually binding. For the installation design, refer to the specific dimensional drawing available on request.

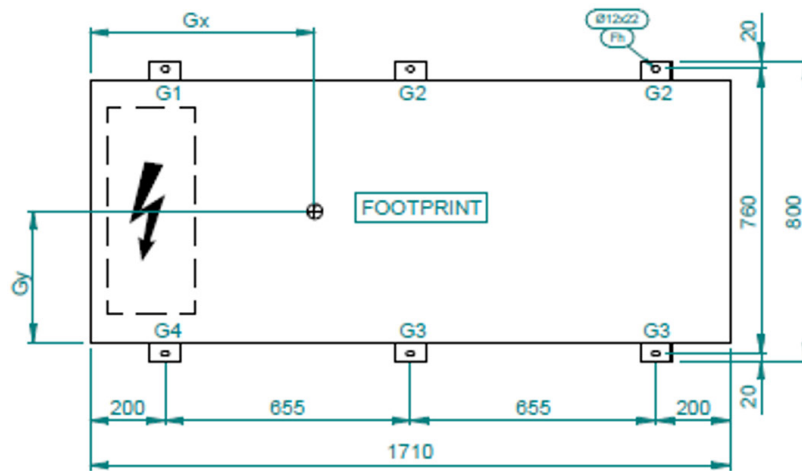

MODEL	WEIGHT (kg)	OPERATING W (kg)	G1 (kg)	G2 (kg)	G3 (kg)	G4 (kg)	Gx	Gy
GEYSER SKY HP 20	411	418	104	60	52	90	728	427
GEYSER SKY HP 20 1P	435	442	110	63	55	96	722	427
GEYSER SKY HP 20 1P+V3I	442	449	113	64	55	98	719	428
GEYSER SKY HP 25	416	423	105	60	53	92	722	424
GEYSER SKY HP 25 1P	439	446	112	63	55	98	720	426
GEYSER SKY HP 25 1P+V3I	447	454	116	64	55	100	717	428

Note: These drawings are not contractually binding. For the installation design, refer to the specific dimensional drawing available on request.

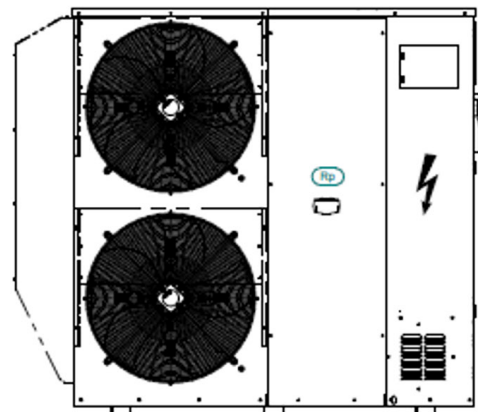
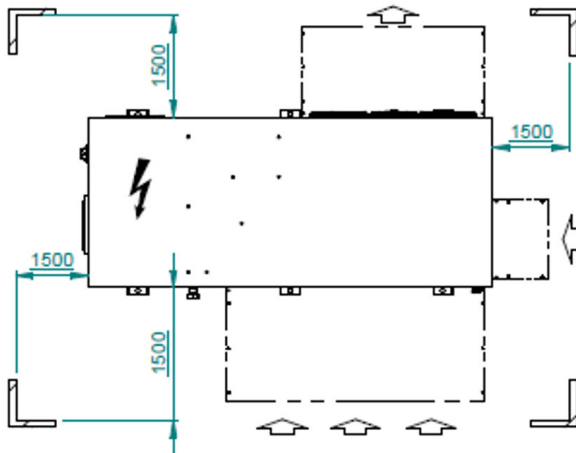
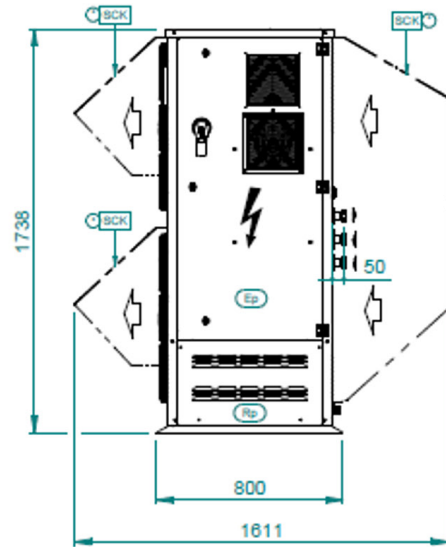
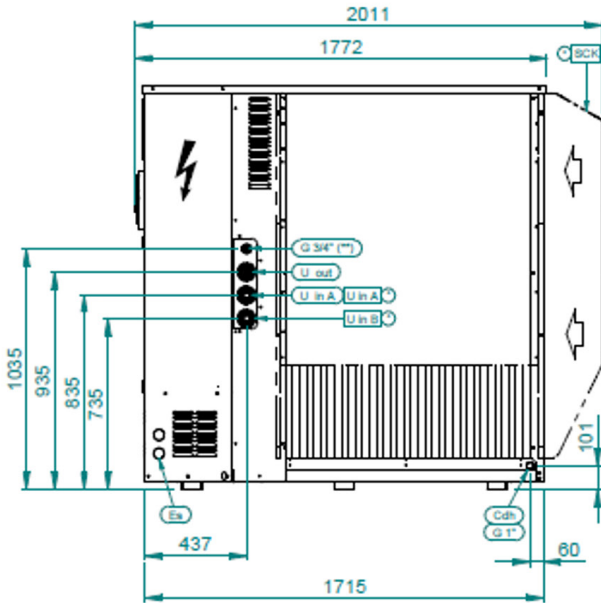

* OPTIONAL

** SAFETY VALVE DISCHARGE

SCK Snow covers kit

CONNECTIONS DIMENSIONS				
HYDR.CONFIG	SIZE	U in A	U in B	U out
GEYSER SKY HP	30	G 1"1/4	/	G 1"1/4
GEYSER SKY HP 1P	30	G 1"1/4	/	G 1"1/4
GEYSER SKY HP 1P+V3I	30	G 1"1/4	G 1"1/4	G 1"1/4

Note: These drawings are not contractually binding. For the installation design, refer to the specific dimensional drawing available on request.

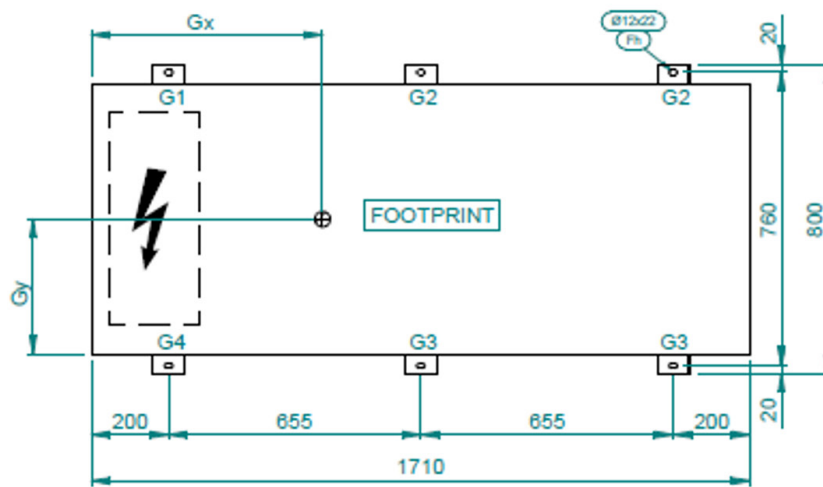

MODEL	WEIGHT (kg)	OPERATING W (kg)	G1 (kg)	G2 (kg)	G3 (kg)	G4 (kg)	Gx	Gy
GEYSER SKY HP 30	422	429	103	62	55	92	735	423
GEYSER SKY HP 30 1P	442	449	110	64	57	97	729	423
GEYSER SKY HP 30 1P+V3I	449	458	113	65	57	99	728	424

Note: These drawings are not contractually binding. For the installation design, refer to the specific dimensional drawing available on request.

Swegon Operations s.r.l.

Via Valletta, 5 - 30010

Cantarana di Cona, (VE) Italy - T. +39 0426 921111 - F. +39 0426 302222

www.blueboxcooling.com - info@bluebox.it



Swegon Operations s.r.l. a socio unico - P.IVA 02481290282

Company directed and coordinated by Investment Latour (Sweden)